

SMART
MACHINE TOOL

SV3

**Installation
Packet**

Important !

- The input voltage to the machine should be 3-phase, 220V, 60 Hz.
- A power transformer will be required if the machine voltage is other than 220 V AC.
- A voltage stabiliser is necessary if the machine is used in situations where the fluctuations in the input voltage are more than 5% of the specified voltage.
- Cooling of the control cabinet by means of an AC or HEAT EXCHANGER unit (as per surrounding temperature) is recommended for ensuring better performance of the system.

NOTE: ALL MACHINES ARE DELIVERED WITH FLUIDS IN THEM. PLEASE CHECK TO VERIFY AT INSTALLATION.

EXCEPTION: MACHINES THAT ARE DELIVERED WITHOUT THE CHILLER UNIT INSTALLED WILL REQUIRE CHILLER FLUID.

SV-3 Floor Space Diagram with chip conveyor For reference only

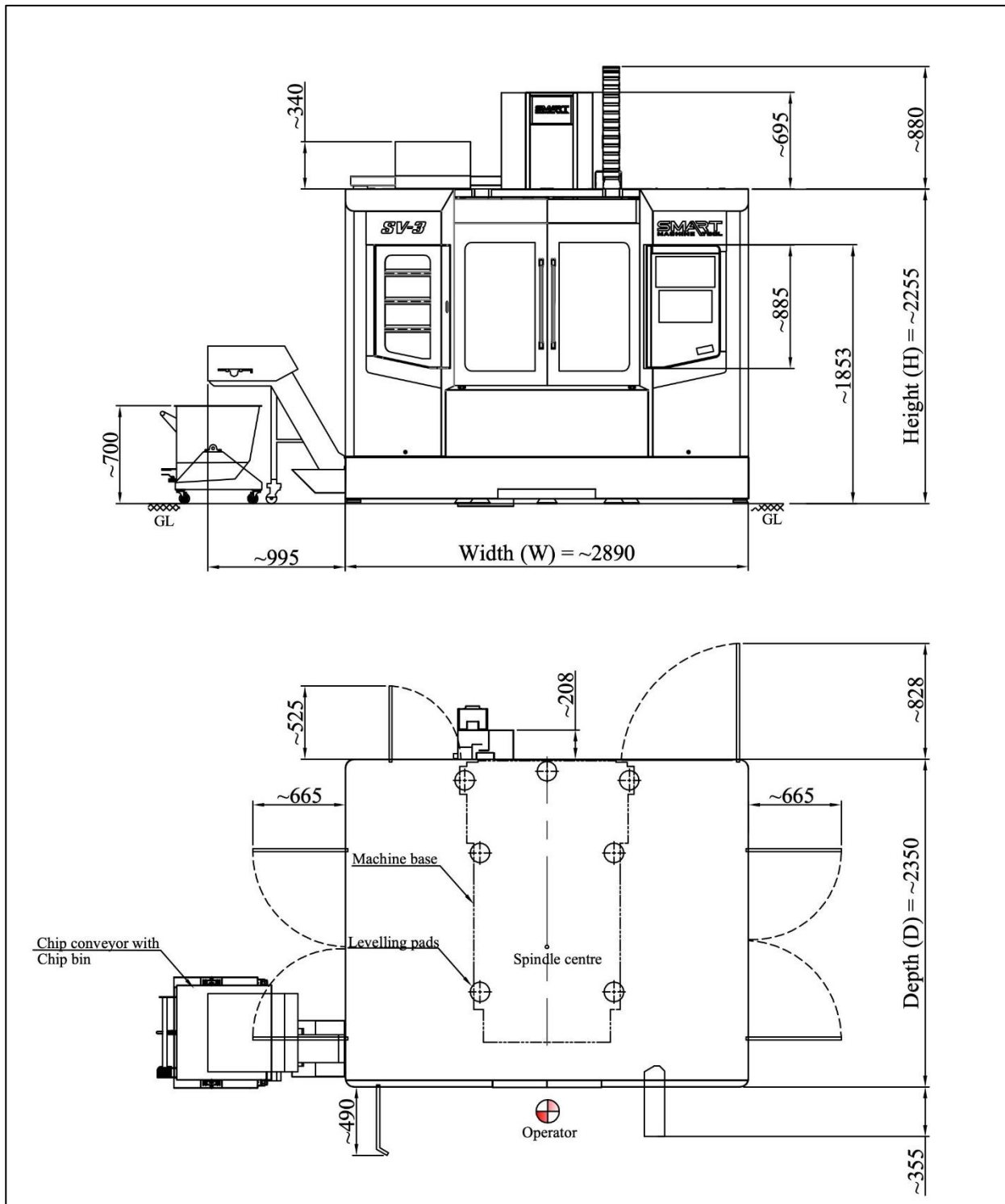

Foundation (Refer to Sheet)

When the ground is level and sufficiently strong, special foundation work is not necessary for installing the machine. Special foundation is necessary in the following cases:

- (a) The ground is weak and may cause sinking or inclination of the ground.
- (b) Higher accuracy and performance is required.
- (c) High-accuracy machining is to be retained for a long time.
- (d) It is recommended to check every year or every 6-8 months after installation that the concrete foundation is stable.
- (e) After installation of the machine, the flatness and straightness of the work table must be checked and corrected using spirit level. Permissible values are 0.020 mm.
- (f) Move work table and saddle to middle stroke position. Keep the spirit level at the centre of the work table and adjust the screws if required. Correct the Squareness between spindle and work table.

Once levelled properly, the machine can maintain the accuracy and assure normal working.

Air source

Air Quality	ISO 8573-1 Class 4 Clean, Dry, NO OIL, NO WATER
Minimum pressure From Air Dryer	6 bar (87 psi)
Max Air Consumption	5.5 CFM / 150 LPM

Removal of axis lock plates



CAUTION

- Remove the axis lock plates from the slides before turning the power On.
- Upon delivery, the axis lock plates are used for transportation. Ensure that they are removed before operating the machine. These lock plates can be retained and reused whenever the machine is moved again.

Lifting diagram

While lifting the machine, refer details as given below:-

Model	Unit	SV-1	SV-2	SV-3	SV-5
Net Weight	Kg	3400	4800	6100	8500

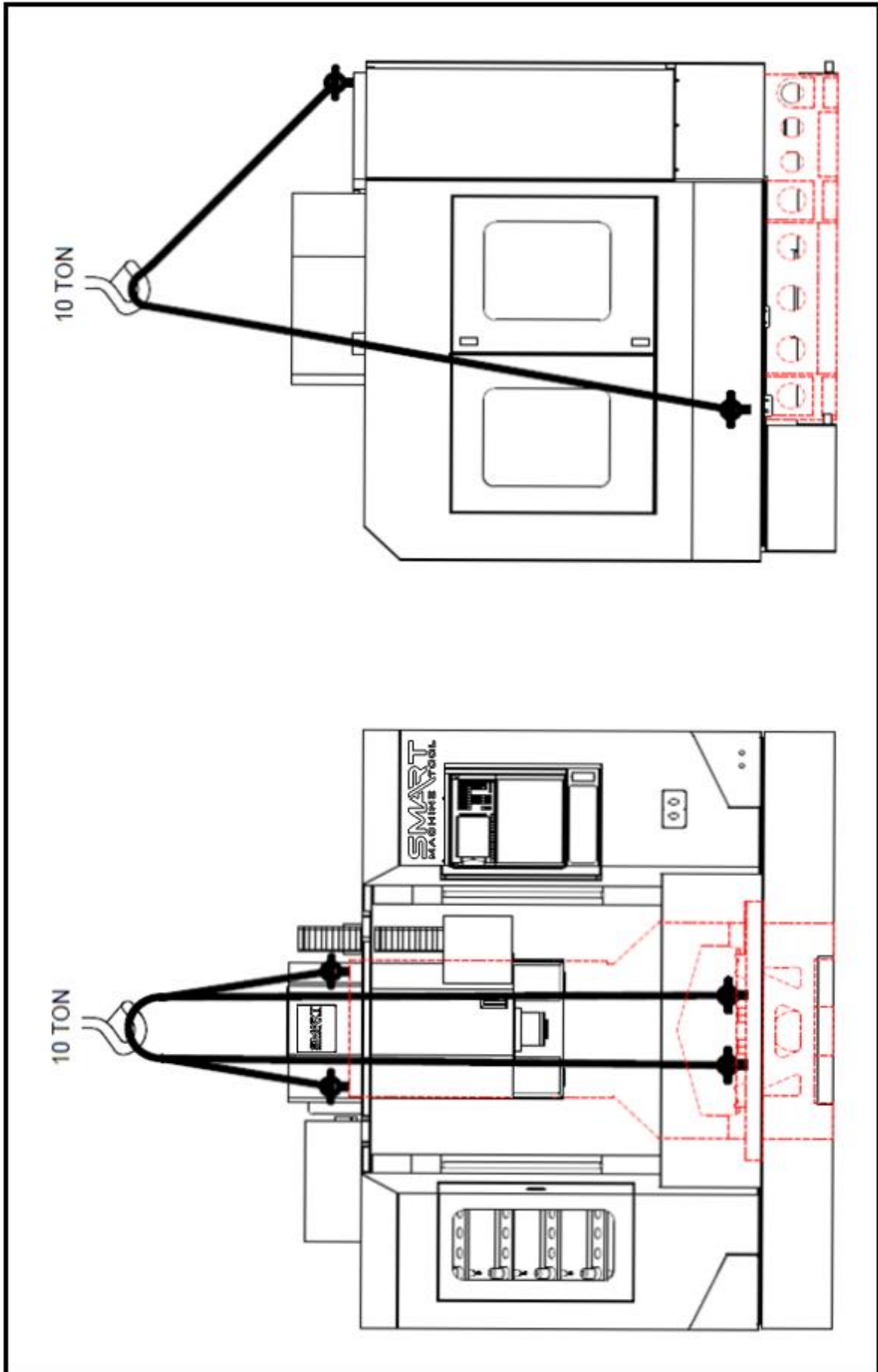

Electrical wiring and power connection

Use the following primary power source and cables:

(a) Supply voltage:

220 V, 60Hz, 3-phase. Refer 2.9 for detailed information.

If a different power supply voltage is in service in a country where the machine is being installed, then a suitable transformer must be provided.

(b) Cable (from the primary power source to the electric cabinet of the machine):

Cable size: Refer 2.9 for detailed information.

The voltage between neutral and earth must be less than 3V.

(c) Grounding:

- Grounding must be done only by officially qualified electricians.
- Use only one grounding conductor for one cable. As a rule, always connect ground cables as shown in the figure below, as otherwise, serious accidents might be caused.
- Never share grounding with any equipment that may generate noise.
- Always ground separately.
- Type C / D Chemical Earth

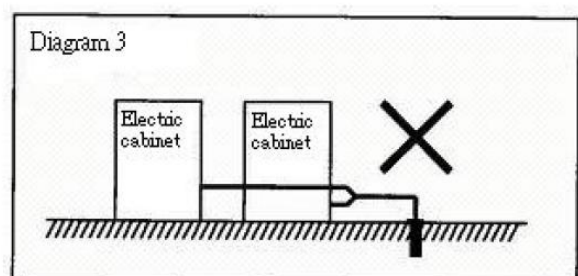
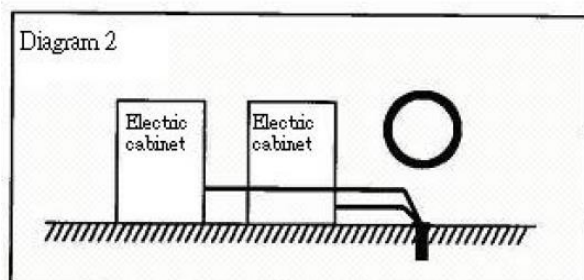
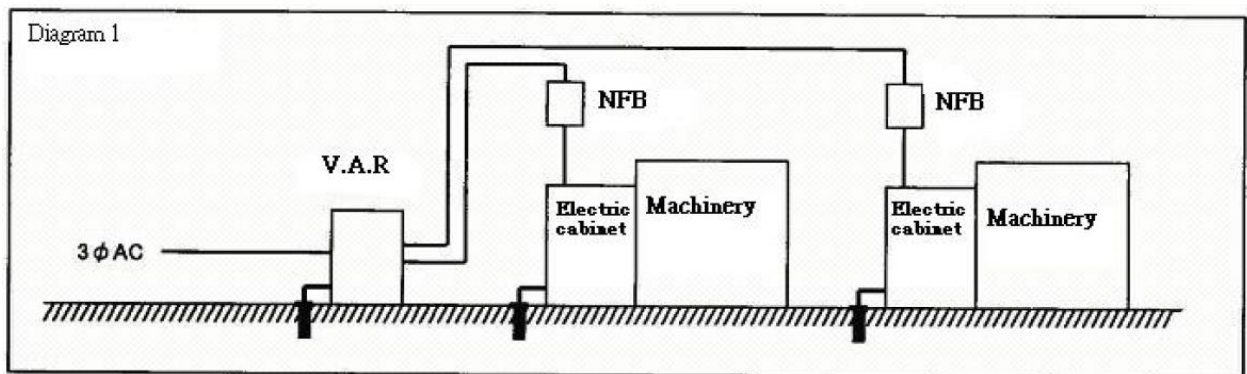

Installation instructions for the machine



WARNING

- Only qualified personnel are authorised to carry out power connections.
- In order to prevent anyone from turning Power on by mistake during power connection, place a tag or placard reading “Never turn Power On” at a prominent place.

1. Connect the mains cable to R, Y, B and PE.

Input Voltage	220V, 3 Phase AC
Maximum voltage fluctuation	± 5%
Maximum line to line fluctuation	5%
Frequency	60Hz
Type of Earthing	Type C / D Chemical Earthing
Voltage Stabilizer	Required. Refer the below table for capacity
Isolation Switch for Stabilizer	100 A as per capacity

Machine Model	Power Capacity	Cable Size	Rating of Isolation Switch
SV-1	20 KVA	10 mm ²	50 A
SV-2	25 KVA	16 mm ²	100 A
SV-3	25 KVA	16 mm ²	100 A
SV-5	35 KVA	16 mm ²	100 A

2. Connect ground terminal to PE.
3. Coolant Motor, Flush Coolant Motor, Coolant through tool motor arrange as per drawing of coolant tank & make electrical connection for the same.
4. Perform checking as follows:
 - Check for proper earth connections and 3-phase input supply connection.
 - Check for the 3-phase input supply.
 - Put on the Main Switch.
 - Press NC ON push button.  The display appears.
 - Release all Emergency Stops (on the machine operator panel and chip conveyor panel if available).
 - Now the machine is ready for operation.

Installation, Operation & Maintenance Manual

Machine specifications

Machine Specifications - All Machines – SV Series					
Specifications	Unit	SV-1	SV-2	SV-3	SV-5
Traverse					
X-Axis Travel	mm	600	800	1100	1300
Y-Axis Travel	mm	450	500	600	700
Z-Axis Travel	mm	500	500	600	700
Spindle nose to table surface	mm	100-600	100-600	150-750	150-850
Spindle Centre to Z-Axis Telescopic Cover	mm	475	520	650	715
Table					
Table Dimension	mm x mm	750 X 450	1000 X 500	1250 X 600	1450 X 650
Table Loading Capacity	Kg	300	500	1000	1500
No./Width/CD of T-Slots	No./mm/mm	5/18/80	5/18/100	5/18/100	5/18/125
Spindle					
Spindle Speed	rpm	10000	10000	10000	10000
Spindle speed (optional)	rpm	12000	12000	12000	12000
Spindle Power (Fanuc)	kW	7.5/11/15	11/15/18.5	11/15/18.5	11/15/18.5
Taper	-	Big Plus CAT 40	Big Plus CAT 40	Big Plus CAT 40	Big Plus CAT 40
Axis Drive					
Rapid Traverse X/Y/Z Axes	m/min.	48/48/48	48/48/48	36/36/36	30/30/30
Cutting Feed rates	m/min.	10	10	10	10
Auto Tool Changer (ATC) BT40 (BT50)					
ATC Type	-	Arm Type	Arm Type	Arm Type	Arm Type
No. of Tools	No's	24	30	30	30
Max. Tool Length	mm	250	250	250	250
Max. Tool Weight	Kg	7	7	7	7
Tool Diameter (with adjacent tool)	mm	75	75	75	75
Tool Diameter (without adjacent tool)	mm	150	150	150	150
Tool Changing Time (Tool to Tool)	Sec.	2.5	2.5	2.5	2.5
Accuracy					
Positioning Accuracy	mm	0.01	0.01	0.01	0.01
Repeatability	mm	± 0.003	± 0.003	± 0.003	± 0.003

Installation, Operation & Maintenance Manual

Specifications	Unit	SV-1	SV-2	SV-3	SV-5
Installation Data					
Floor Space (including basic coolant system)	W x D	2060 x 1990	2430 x 2100	2900 x 2350	3500 x 2580
Floor Space (with Lift Up Conveyor)	W x D	2060 x 2920	3420 x 2100	3890 x 2350	4990 x 2580
Net Weight (with ATC)	Kg	3400	4800	6100	8500
Power Capacity (Fanuc)	kVA	20	25	25	35
Air Supply (Pressure Flow rate)	-	6 Bar 200LPM	6 Bar 200LPM	6 Bar 200LPM	6 Bar 200LPM
Power Supply	-	220V, 60Hz, 3Phase	220V, 60Hz, 3Phase	220V, 60Hz, 3Phase	220V, 60Hz, 3Phase

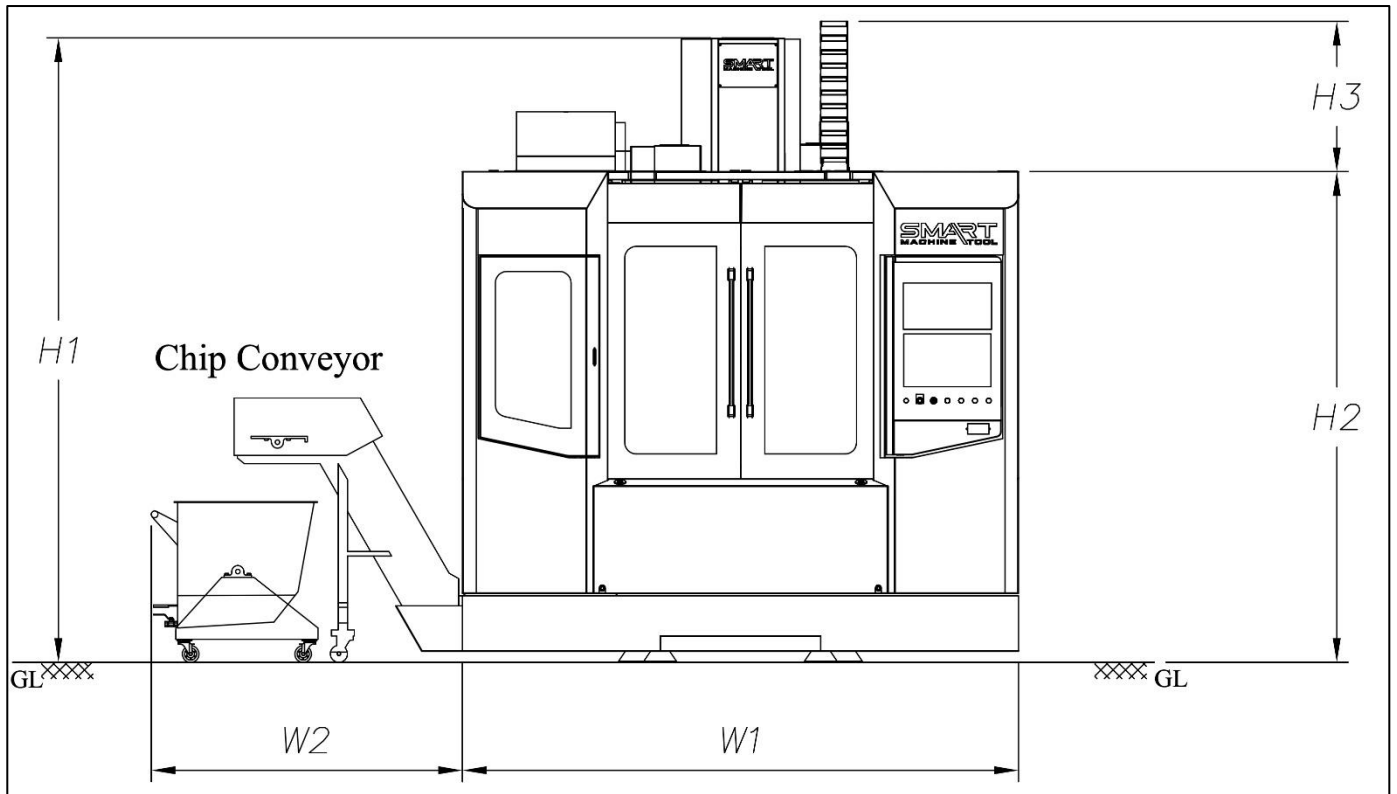

Machine Dimension - SV Series

	SV-1	SV-2	SV-3	SV-5
W1	1940	2430	2890	3500
W2	-	1410	1410	1410
H1	2625	2725	2950	2700
H2	1955	2140	2255	2400
H3	820	655	880	800
DEPTH	2990	2450	2700	2800
All Dimensions in mm				
Note : Dimension don't include accessories & space for maintenance				

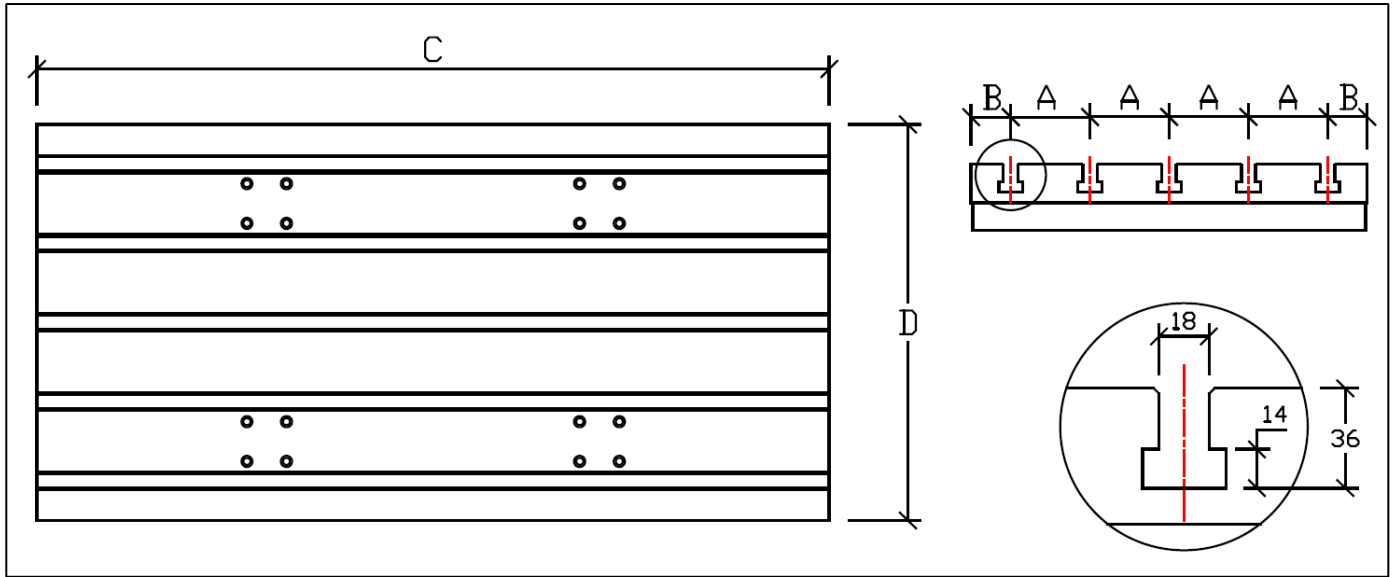
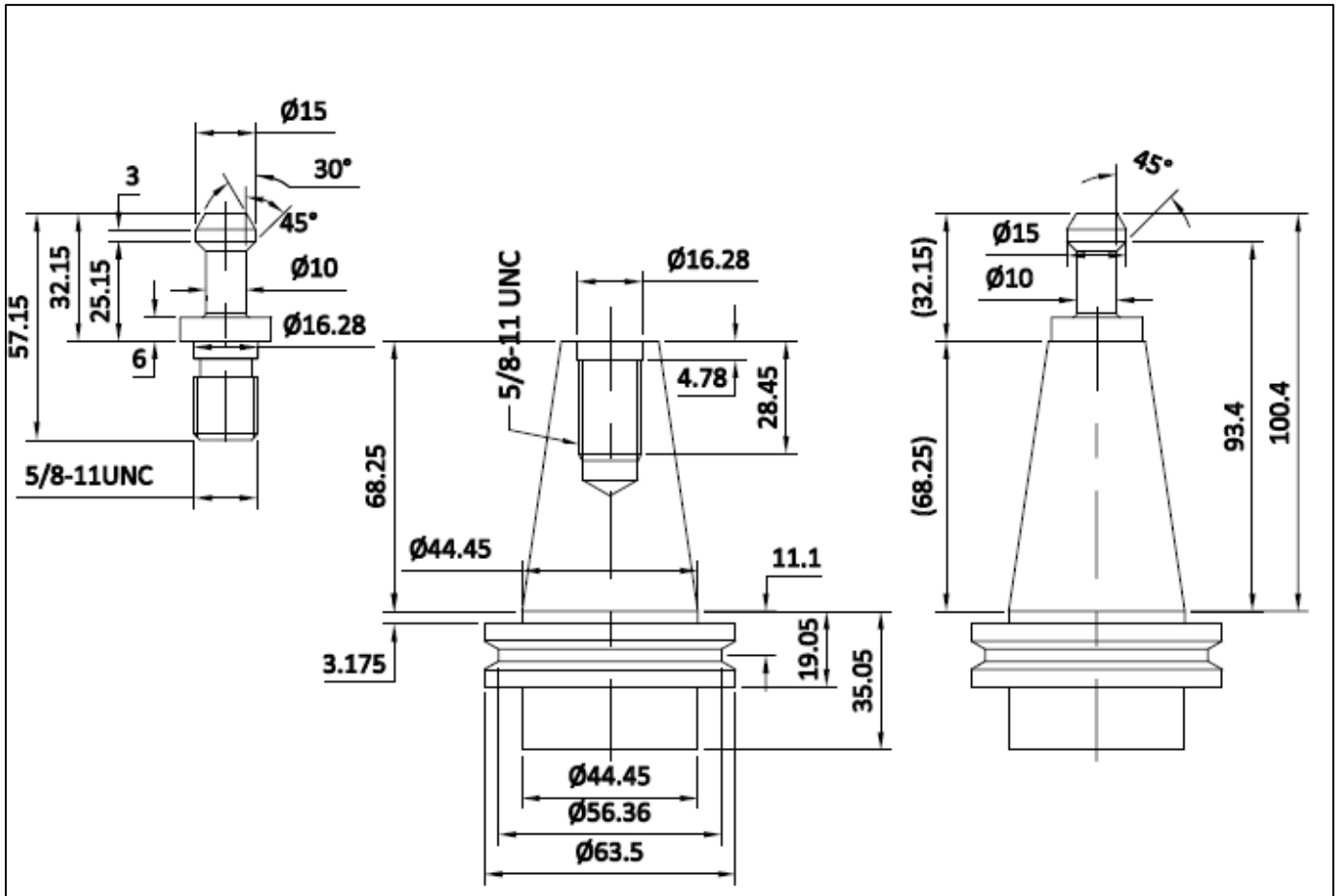

Table Dimension - SV Series

	SV-1	SV-2	SV-3	SV-5
A	80	100	100	125
B	65	50	100	75
C	750	1000	1250	1450
D	450	500	600	650

Pull Stud Information

CAT 40 Pull Stud and Tool holder



Points to be lubricated and brands of oil

Sl. No.	Parts to be lubricated	ISO Grade	IOC	HP	CASTROL	BPCL
01	X/Y/ Z - axis Guideways & Ball screws	VG68	SERVO WAY 68	WAY LUB 68	Meghna BD 68	Motomol 68
02	Spindle Oil chiller	VG32	SERVO SYSTEM 32 SER	ENKLO 32	Hyspin AWS 32	Hydrol S 32
03	ATC gearbox	VG150	SERVO MESH SP150	Parthen EP 150	Alpha SP 150	Amocam oil 150
04	4th Axis	VG150	SERVO MESH SP150	Parthen EP 150	Alpha SP 150	Amocam oil 150
05	FRL	VG32	SERVO SYSTEM 32 SER	ENKLO 32	Hyspin AWS 32	Hydrol S 32

Lubrication System

- Centralized is used for lubrication on for LM guide and ball screw of all 3 axes.
- Interval for lubrication: Controlled by PLC (Settable by user).

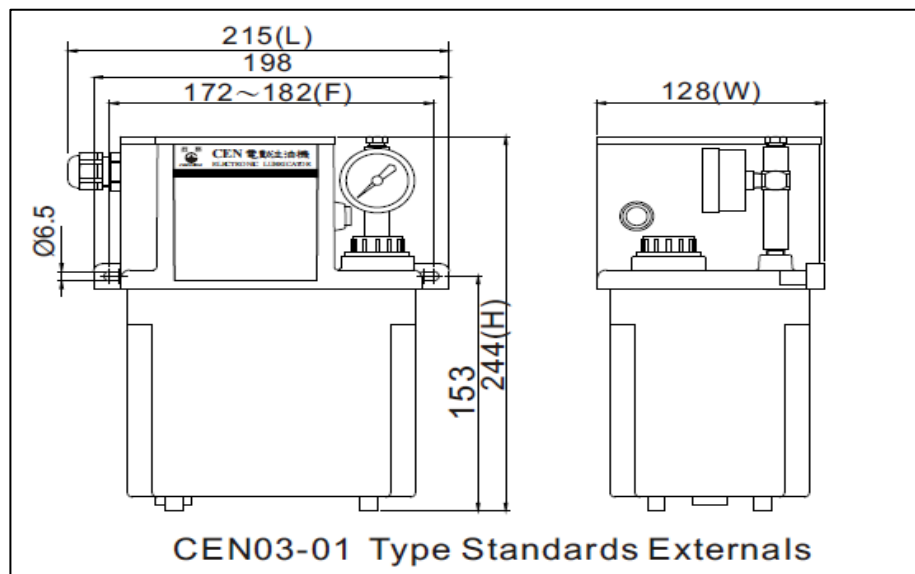

Yearly check-ups

No.	Check point	Check item	Remarks
01	Lubrication pump unit	Replace the suction filter	
02	Electrical cabinet	Replace dry batteries. Also replace it upon receiving the “Battery Low”	

Pneumatic Circuit check-ups

1. Main Pressure switch setting: 5 to 6 kg/cm²
2. Spindle labyrinth blast setting should be 2 kg/cm²
3. Air Input: Dry and clean air 200 LPM and with 6 to 7 kg/cm² (use std. air drier)
4. Lubricator: VG 32 oil - Fill whenever empty.

Spindle oil chiller:

Specification:

Sr. No.	Parameter	All SV Models
1	Name	Spindle Oil Chiller
2	Make	Advance Cooling Systems Pvt. Ltd.
3	Model	DO 4PTSA
7	Refrigerant	R134a / 0.35 kg
8	Tank capacity	13 litre, 76 Kg

Temp. Setting Range:

- Fixed Temperature control: 10° C ~40° C
- Differential temperature control: -5° C ~ +5° C