



SM 600

12K

Installation

Packet

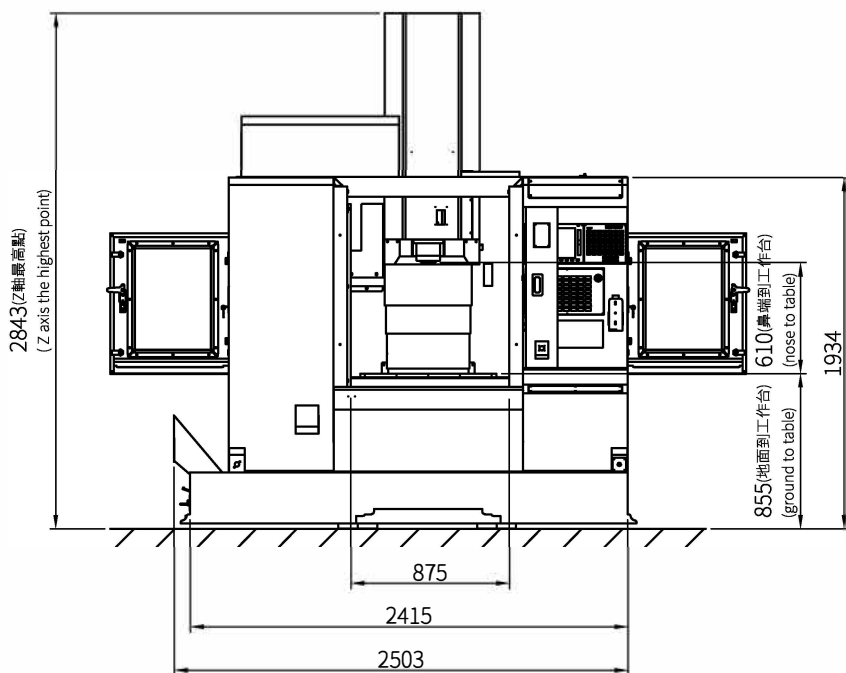
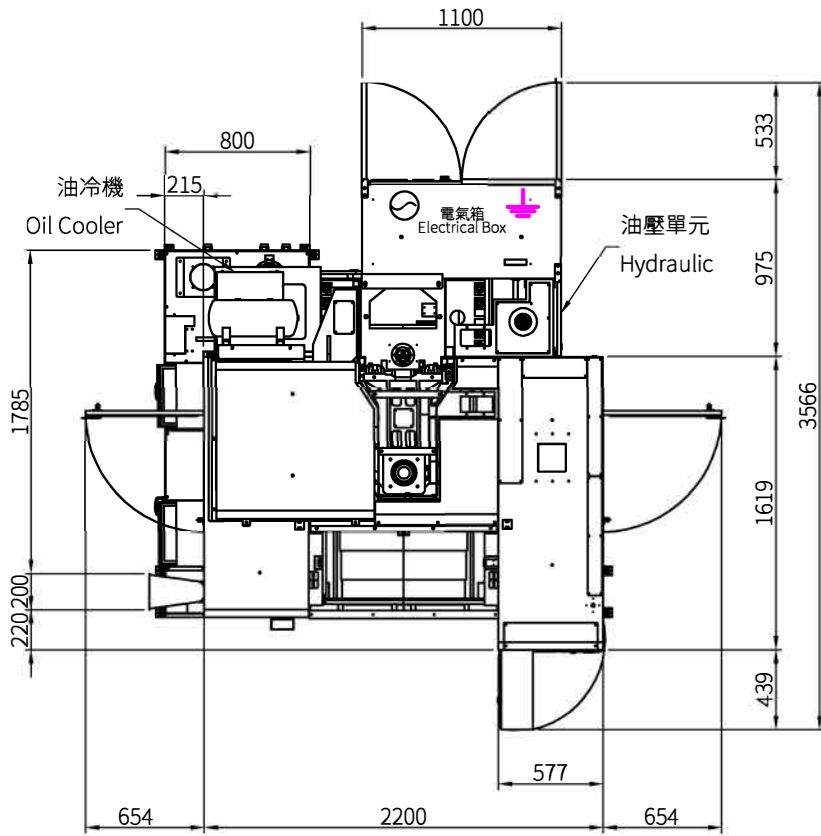



⊕ POWER SUPPLY

⊙ 氣壓源入口
AIR PRESSURE SOURCE

Keep the machine contact with the ground well
Please insert a 22x1.8 meter copper rod
into the ground and confirm that is finished.
The copper rod is the ground wire.
(Ground impedance must be less than 10Ω.)

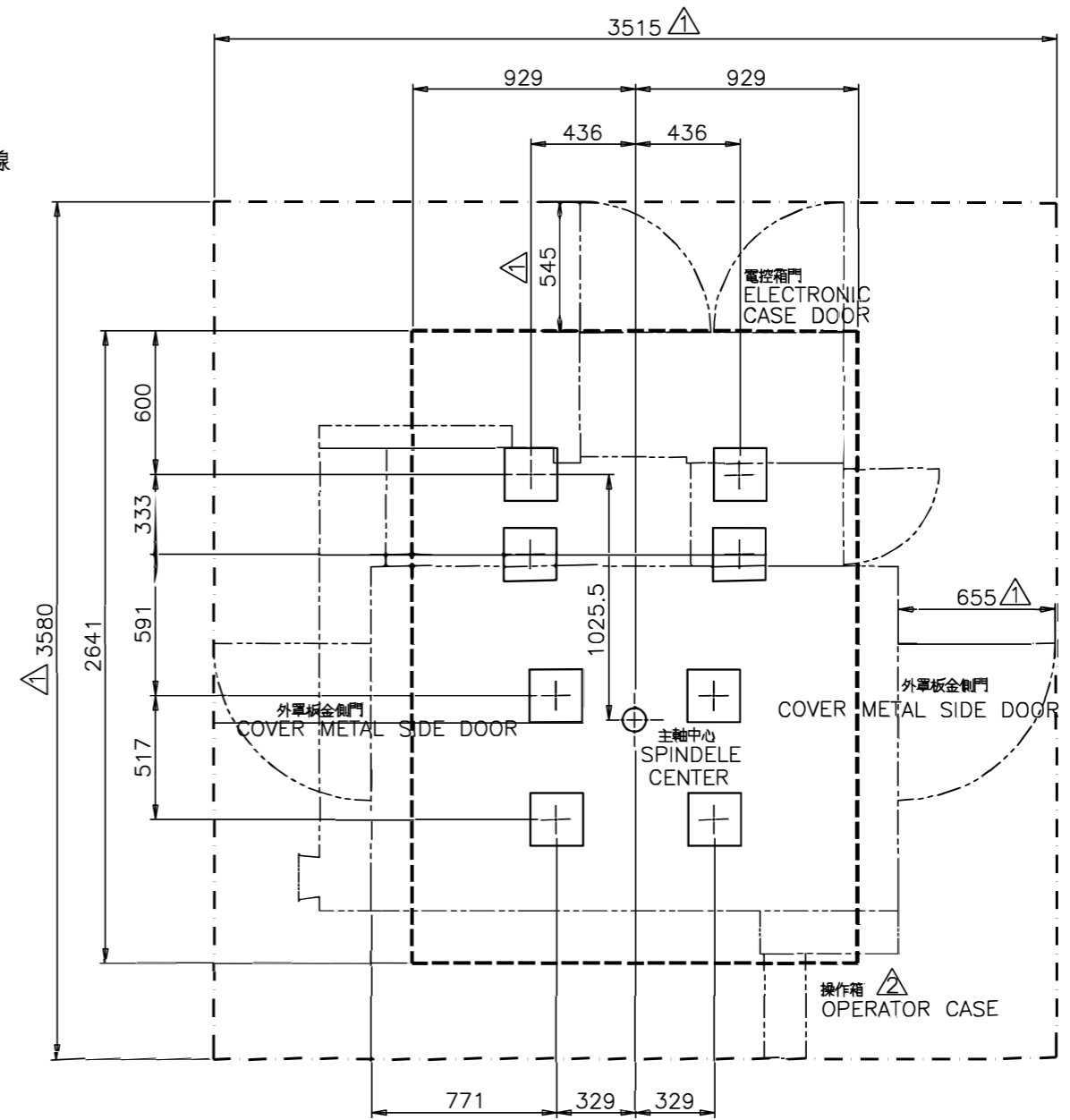
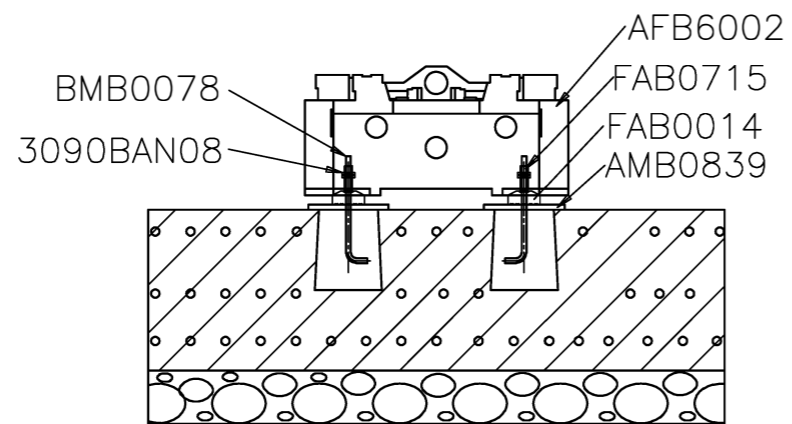
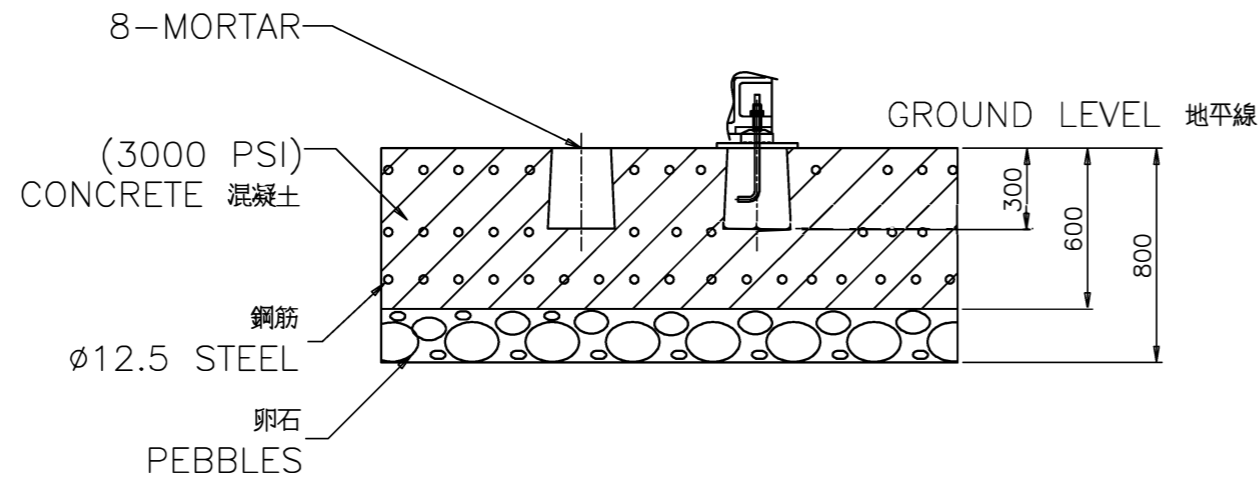



- SPECIAL FOUNDATION
地基範圍
-  MORTAR FOR FOUNDATION SCREWS
埋設地腳螺絲用預留洞
- AREA OF MACHINE BASE
機械本體佔地範圍
- SUGGEST MIN WORKING AREA
操作範圍

#40

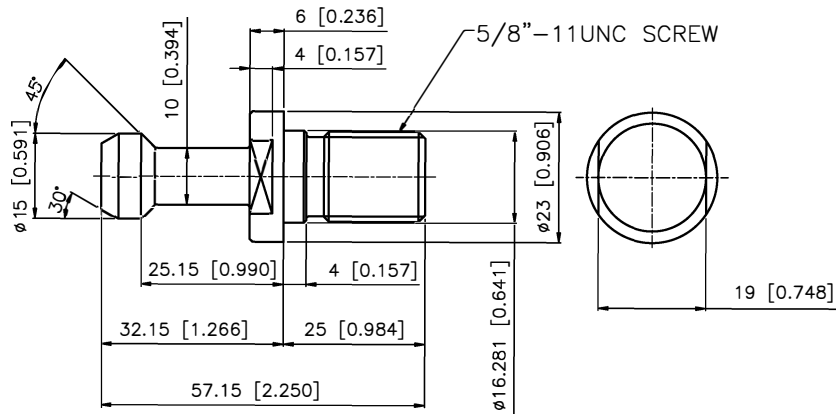

Lyndex PN
Non CTS
C40-4500
CTS
C40-4500H

#50

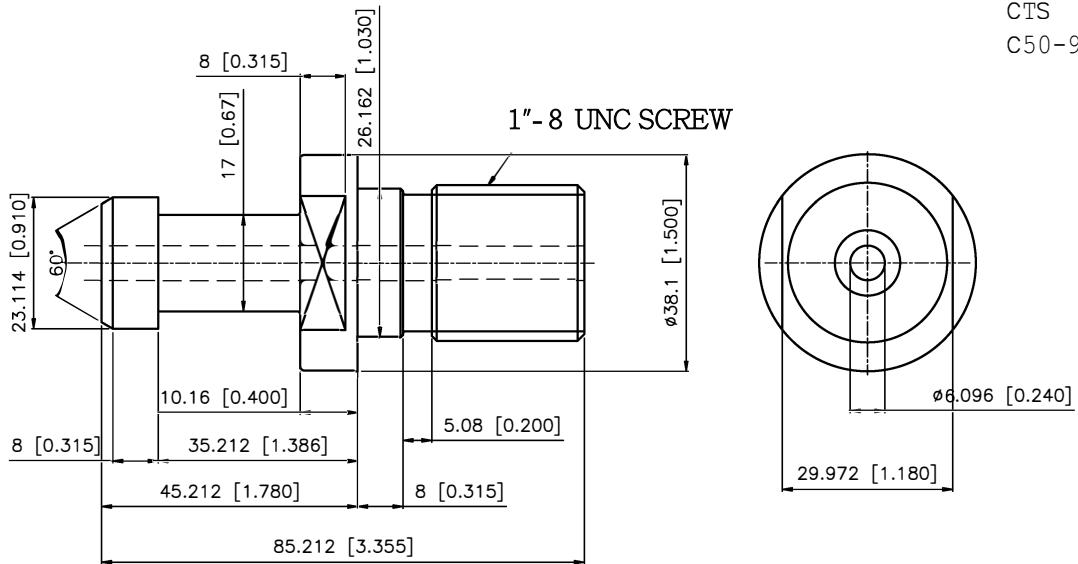

Lyndex PN
Non CTS
C50-9000
CTS
C50-9000H

POWER AND LUBRICATION REQUIREMENTS

2/24/2020 MACHINE MODEL	KVA	AMPS @ 220	Coolant	Slideways	Chilled Geared Headstock	Oil for Air	Chiller OilTank
SM1688	45	118	116 gal	6L	20L	6oz	N/A
SM2600	50	131	360 gal	6L	20L	6oz	N/A
				Shell Tonna S3M68		Mobil DTE Light	Mobil Velocite #3
SM600	25	65	85 gal	4.5L	N/A	6oz	20L
SM1000 12K	25	65	85 gal	4.5L	N/A	6oz	20L
SM965 8K	25	65	95 gal	4.5L	1.2 gal	6oz	N/A
SM965 12K	40	104	95 gal	4.5L	N/A	6oz	20L
SM1165 8K	25	65	99 gal	4.5L	1.2 gal	6oz	N/A
SM1165 12K	40	104	99 gal	4.5L	N/A	6oz	20L
SM1165 6K	40	104	99 gal	4.5L	1.2 gal	6oz	N/A
SM1365 6K	40	104	103 gal	4.5L	1.2 gal	6oz	N/A
SM1365 12K	40	104	103 gal	4.5L	N/A	6oz	20L
SM1565 12K	40	104	105 gal	4.5L	N/A	6oz	20L
SM1565 6K	40	104	105 gal	4.5L	1.2 gal	6oz	N/A
SM1575 12K	40	104	105 gal	4.5L	N/A	6oz	20L
SM800APC	30	78		4.5L	N/A	6oz	20L
SM212/312	40	104	122 gal	4.5L	N/A	6oz	20L
				Shell Tonna S3M68	Mobil DTE 24	Mobil DTE Light	Mobil Velocite #6
				check daily	check daily	check daily	check daily

SM Series:

Air: 8 CFM @ 80-100 PSI

Air Fitting Size: 5/8 DIA. MINIMUM ID

Conestoga Trailers arranged by Walsh Logistics required for machine shipments

Model	Description	ESTIMATED PACKING	
		(Size - FT L x W x H)	(Size - LBS)
SM600 12K	MACHINE	11.25' x 7.6' x 8.4'	10,913
SM1000 12K	MACHINE	13x7.6x8.4'	12,513
SM965-24T	MACHINE	11'2 x 7'7 x 8'3	15,783
SM965-36T	MACHINE	16'1 X 7'7 X 8'2	15,783
SM965-36T	TOOL MAGAZINE	3'1 X 3'8 X 4'2	1,433
SM1165-24T	MACHINE	12'3 X 7'7 X 8'3	15,432
SM1165-36T	MACHINE	16'1 X 7'7 X 8'2	15,432
SM1165-36T	TOOL MAGAZINE	3'1 X 3'8 X 4'2	1,433
SM1165-30T	MACHINE	16'1 X 7'7 X 8'3	16,424
SM1165-30T	TOOL MAGAZINE	3'7 x 5'5 x 5'5	1,984
SM1365-36T	MACHINE	16'3 X 7'7 X 8'1	16,555
SM1365-36T	TOOL MAGAZINE	3'1 X 3'8 X 4'2	1,433
SM1365-30T	MACHINE	16'3 X 7'7 X 8'1	16,755
SM1365-30T	TOOL MAGAZINE	3'7 X 5'4 X 5'6	1,984
SM1565-36T	MACHINE	17'8 x 7'7 x 8'1	18,078
SM1565-36T	TOOL MAGAZINE	3'1 X 3'8 X 4'2	1,433
SM1565-30T	MACHINE	17'8 x 7'7 x 8'1	18,298
SM1565-30T	TOOL MAGAZINE	3'7 x 5'5 x 5'5	1,984
SM1575-36T	MACHINE	13.25'x7.6'x7.6'	19,000
SM1575-36T	TOOL MAGAZINE	3'7 x 5'5 x 5'5	1,984
SM1608	MACHINE & ACCESSORIES	17'9"x12'3"x3'78	39,000
SM1688	MACHINE & ACCESSORIES	17'9 X 13'6 X 11'3	42,064
SM2600	MACHINE	17'9"x13'2"x13'	47,399
SM2600	ACCESSORIES	18'1"x7'6"x6'5"	5,512
SM2600	ACCESSORIES	15'9"x7'6"x7'8"	7,716
SM850-APC	MACHINE	11'9 x 7'7 x 8'3	16,535
SM850-APC	ACCESSORIES(tool magazine, chip conveyor, etc.)	13' x 7'6 x 6'4	3,616
SM212	MACHINE & ACCESSORIES	18'10 x 12'4 x 12'2	39,551
SM312	MACHINE & ACCESSORIES	26'1 x 12'4 x 12'2	49,493
Conestoga not required for SM1688 and SM2600			