

SMART
MACHINE TOOL

SM2500

**Installation
Packet**

d. SM2110/2510

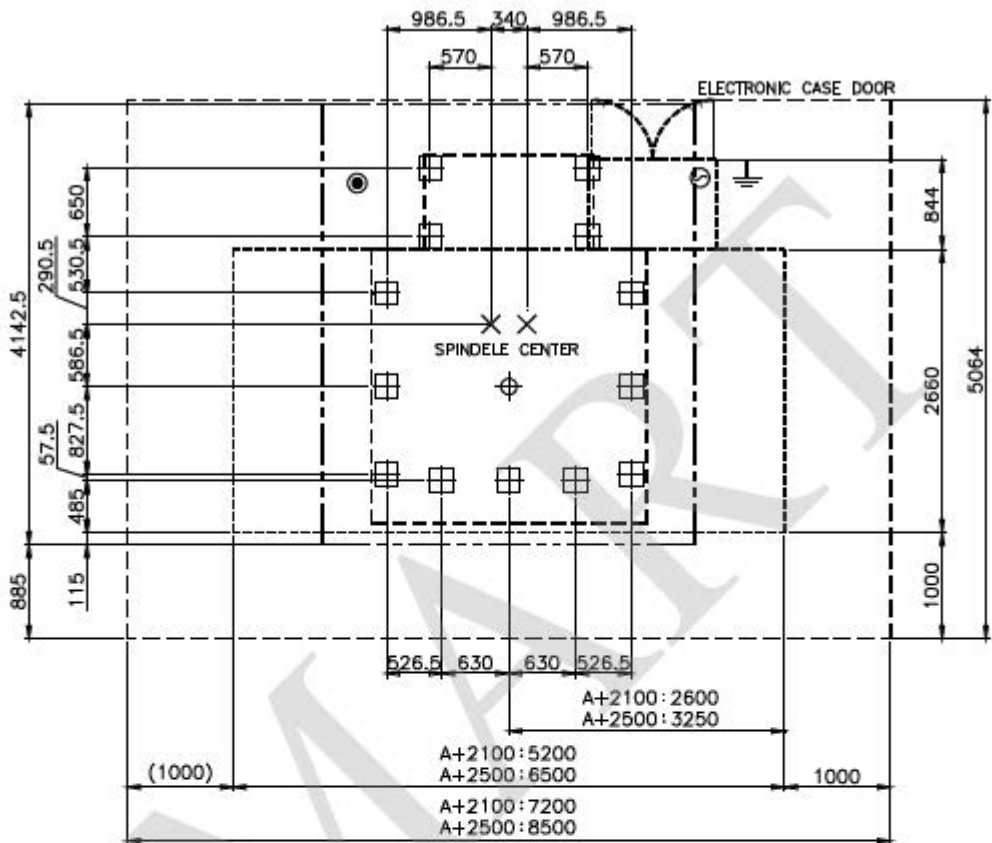

- SPECIAL FOUNDATION
- ☐ MORTAR FOR FOUNDATION SCREWS
- ✕ BOLTS FOR PRELIMINARY ADJUSTMENT (WITHOUT HOLES)
- AREA OF MACHINE BASE
- - - SUGGEST MIN WORKING AREA
- ⊖ POWER SUPPLY
- AIR PRESSURE SOURCE



In order to make the machine ground to achieve good results Please use a \varnothing 22x1.8 meters long copper into the ground And confirm that the copper rod is indeed buried in the soil Finally, with this copper rod as a machine grounding (The final ground impedance should be less than 10 ohms)

POWER AND LUBRICATION REQUIREMENTS

2/24/2020 MACHINE MODEL	KVA	AMPS @ 220	Coolant	Slideways	Chilled Geared Headstock	Oil for Air	Chiller OilTank
SM1688	45	118	116 gal	6L	20L	6oz	N/A
SM2600	50	131	360 gal	6L	20L	6oz	N/A
				Shell Tonna S3M68		Mobil DTE Light	Mobil Velocite #3
SM600	25	65	85 gal	4.5L	N/A	6oz	20L
SM1000 12K	25	65	85 gal	4.5L	N/A	6oz	20L
SM965 8K	25	65	95 gal	4.5L	1.2 gal	6oz	N/A
SM965 12K	40	104	95 gal	4.5L	N/A	6oz	20L
SM1165 8K	25	65	99 gal	4.5L	1.2 gal	6oz	N/A
SM1165 12K	40	104	99 gal	4.5L	N/A	6oz	20L
SM1165 6K	40	104	99 gal	4.5L	1.2 gal	6oz	N/A
SM1365 6K	40	104	103 gal	4.5L	1.2 gal	6oz	N/A
SM1365 12K	40	104	103 gal	4.5L	N/A	6oz	20L
SM1565 12K	40	104	105 gal	4.5L	N/A	6oz	20L
SM1565 6K	40	104	105 gal	4.5L	1.2 gal	6oz	N/A
SM1575 12K	40	104	105 gal	4.5L	N/A	6oz	20L
SM800APC	30	78		4.5L	N/A	6oz	20L
SM212/312	40	104	122 gal	4.5L	N/A	6oz	20L
SM2500	45	118		4.5L	N/A	6oz	20L
				Shell Tonna S3M68	Mobil DTE 24	Mobil DTE Light	Mobil Velocite #6
				check daily	check daily	check daily	check daily

SM Series:

Air: 8 CFM @ 80-100 PSI
 Air Fitting Size: 5/8 DIA. MINIMUM ID
 Voltage: 200-235V

Conestoga Trailers arranged by Walsh Logistics required for machine shipments

Model	Description	ESTIMATED PACKING	
		(Size - FT L x W x H)	(Size - LBS)
SM600 12K	MACHINE	11.25' x 7.6' x 8.4'	10,913
SM1000 12K	MACHINE	13x7.6x8.4'	12,513
SM965-24T	MACHINE	11'2 x 7'7 x 8'3	15,783
SM965-36T	MACHINE	16'1 X 7'7 X 8'2	15,783
SM965-36T	TOOL MAGAZINE	3'1 X 3'8 X 4'2	1,433
SM1165-24T	MACHINE	12'3 X 7'7 X 8'3	15,432
SM1165-36T	MACHINE	16'1 X 7'7 X 8'2	15,432
SM1165-36T	TOOL MAGAZINE	3'1 X 3'8 X 4'2	1,433
SM1165-30T	MACHINE	16'1 X 7'7 X 8'3	16,424
SM1165-30T	TOOL MAGAZINE	3'7 x 5'5 x 5'5	1,984
SM1365-36T	MACHINE	16'3 X 7'7 X 8'1	16,555
SM1365-36T	TOOL MAGAZINE	3'1 X 3'8 X 4'2	1,433
SM1365-30T	MACHINE	16'3 X 7'7 X 8'1	16,755
SM1365-30T	TOOL MAGAZINE	3'7 X 5'4 X 5'6	1,984
SM1565-36T	MACHINE	17'8 x 7'7 x 8'1	18,078
SM1565-36T	TOOL MAGAZINE	3'1 X 3'8 X 4'2	1,433
SM1565-30T	MACHINE	17'8 x 7'7 x 8'1	18,298
SM1565-30T	TOOL MAGAZINE	3'7 x 5'5 x 5'5	1,984
SM1575-36T	MACHINE	13.25'x7.6'x7.6'	19,000
SM1575-36T	TOOL MAGAZINE	3'7 x 5'5 x 5'5	1,984
SM1608	MACHINE & ACCESSORIES	17'9"x12'3"x378	39,000
SM1688	MACHINE & ACCESSORIES	17'9 X 13'6 X 11'3	42,064
SM2600	MACHINE	17'9"x13'2"x13'	47,399
SM2600	ACCESSORIES	18'1"x7'6"x6'5"	5,512
SM2600	ACCESSORIES	15'9"x7'6"x7'8"	7,716
SM850-APC	MACHINE	11'9 x 7'7 x 8'3	16,535
SM850-APC	ACCESSORIES(tool magazine, chip conveyor, etc.)	13' x 7'6 x 6'4	3,616
SM212	MACHINE & ACCESSORIES	18'10 x 12'4 x 12'2	39,551
SM312	MACHINE & ACCESSORIES	26'1 x 12'4 x 12'2	49,493
SM2500	MACHINE & ACCESSORIES	30.75x13x13	63,978
Conestoga not required for SM1688 and SM2600			

#40

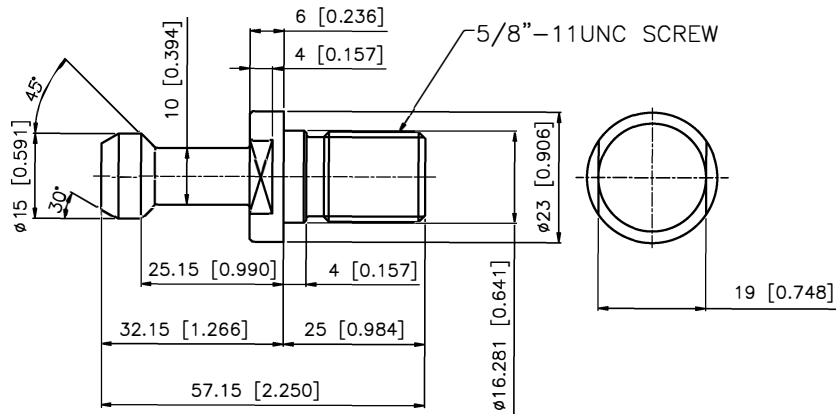

Lyndex PN
Non CTS
C40-4500
CTS
C40-4500H

#50

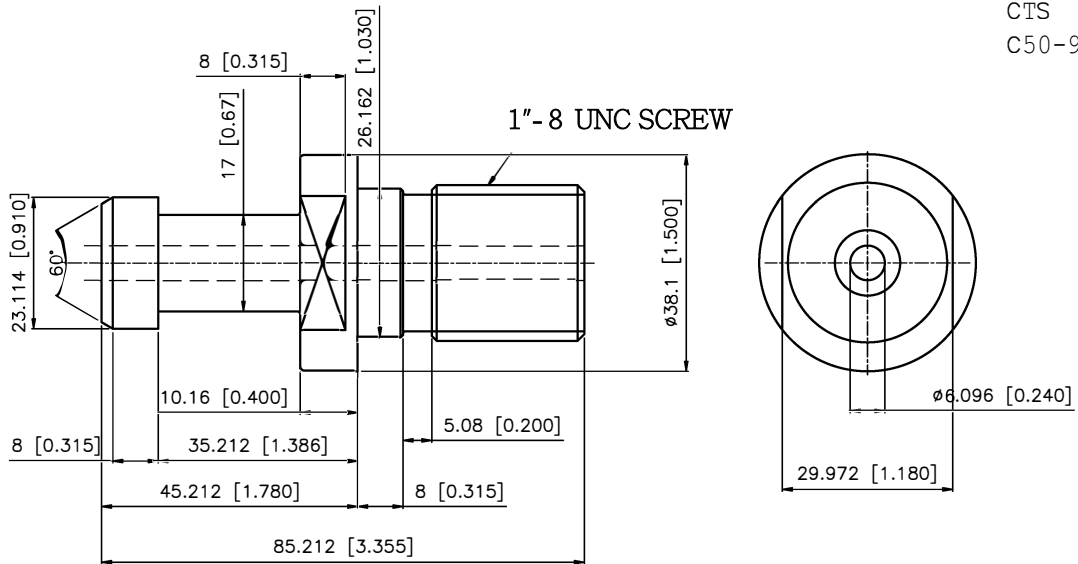

Lyndex PN
Non CTS
C50-9000
CTS
C50-9000H