

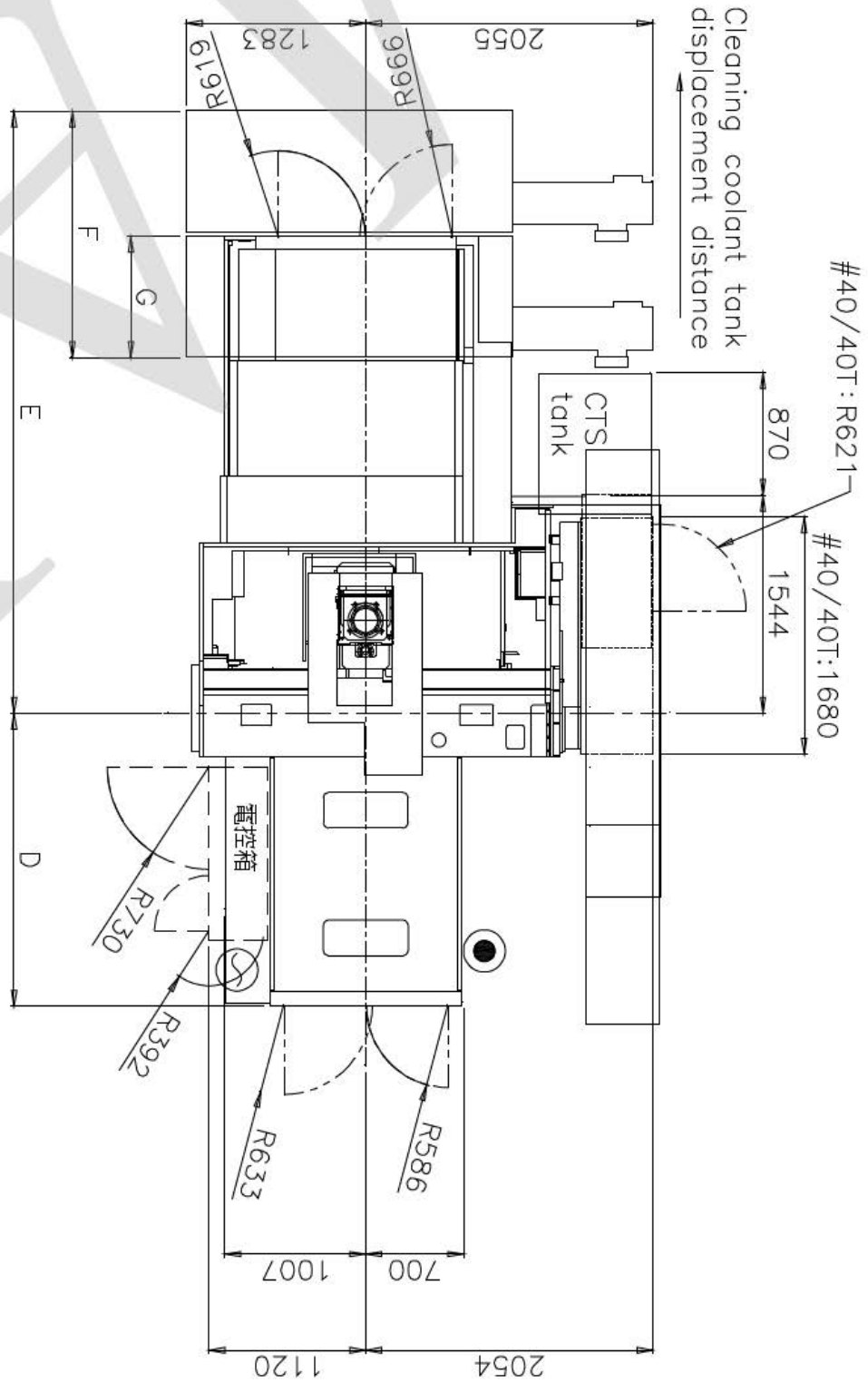

SM 212/312

**Installation
Packet**



Unit : mm

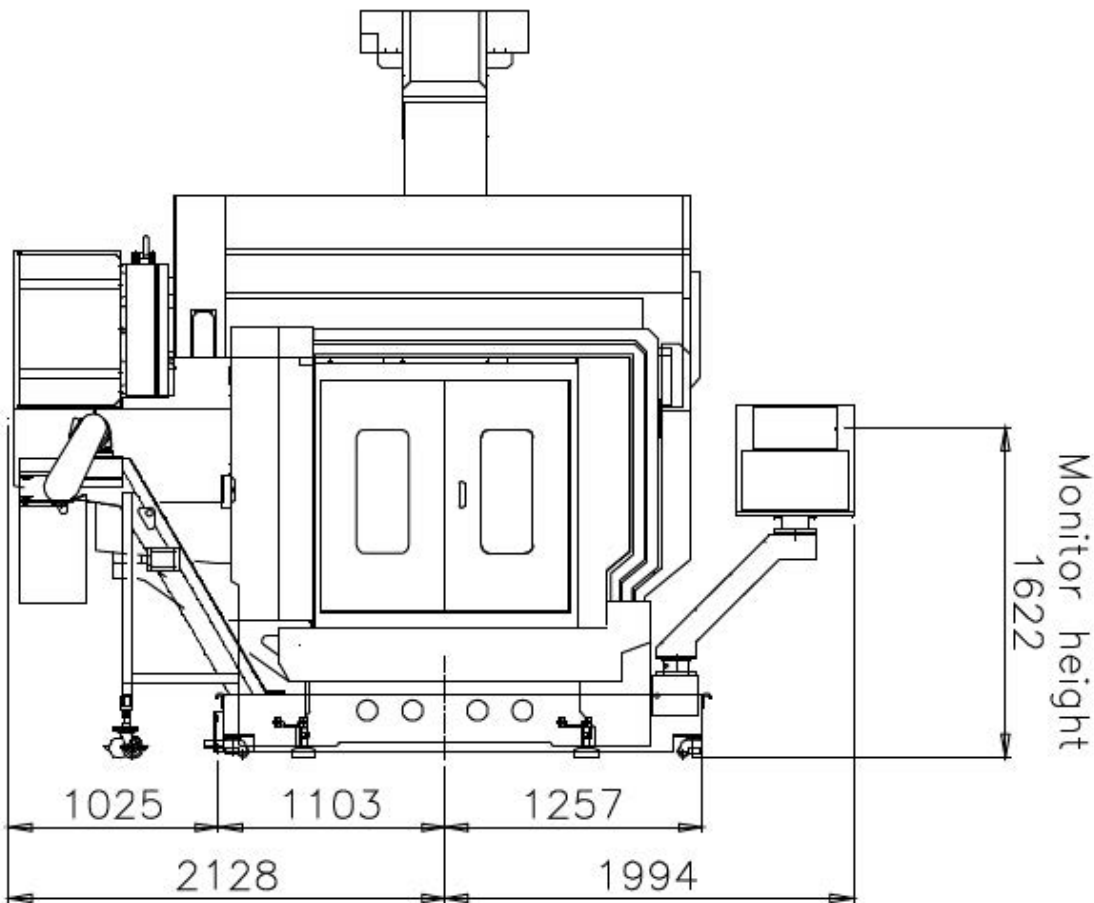
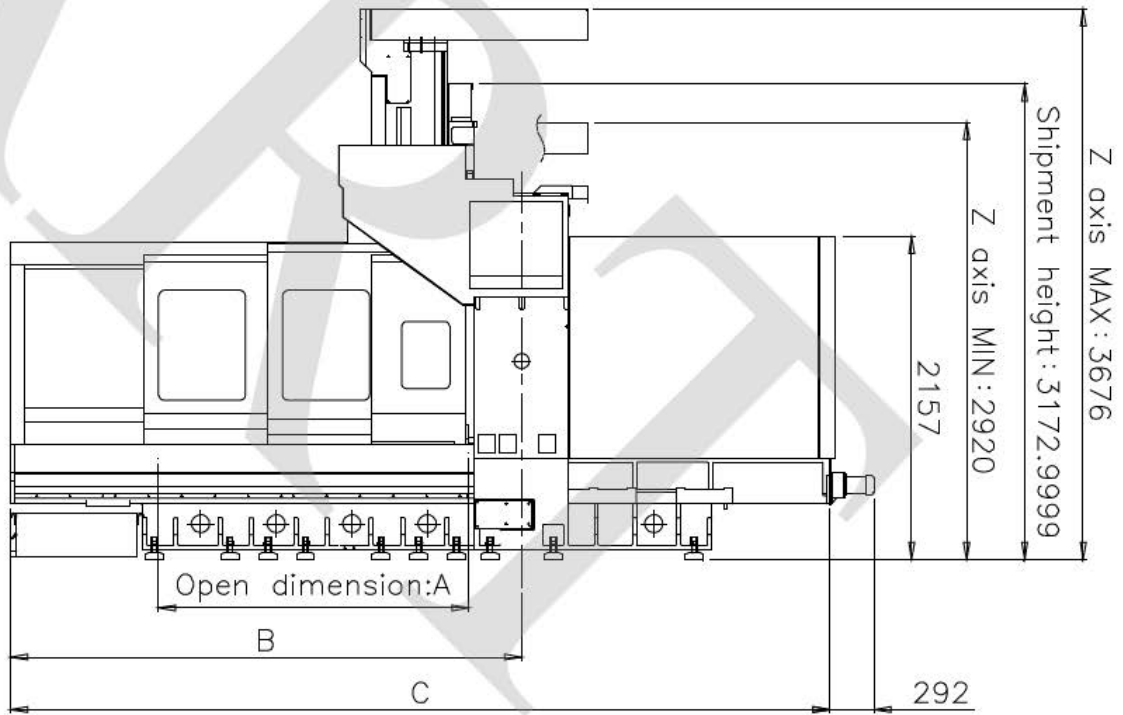

(Unit : mm)

Size	Type	SM212	SM312
A		2057	3060
B		3383	4381
C		5425	7425
D		2082	3082
E		4270	5302
F		860	860
G		1750	1750

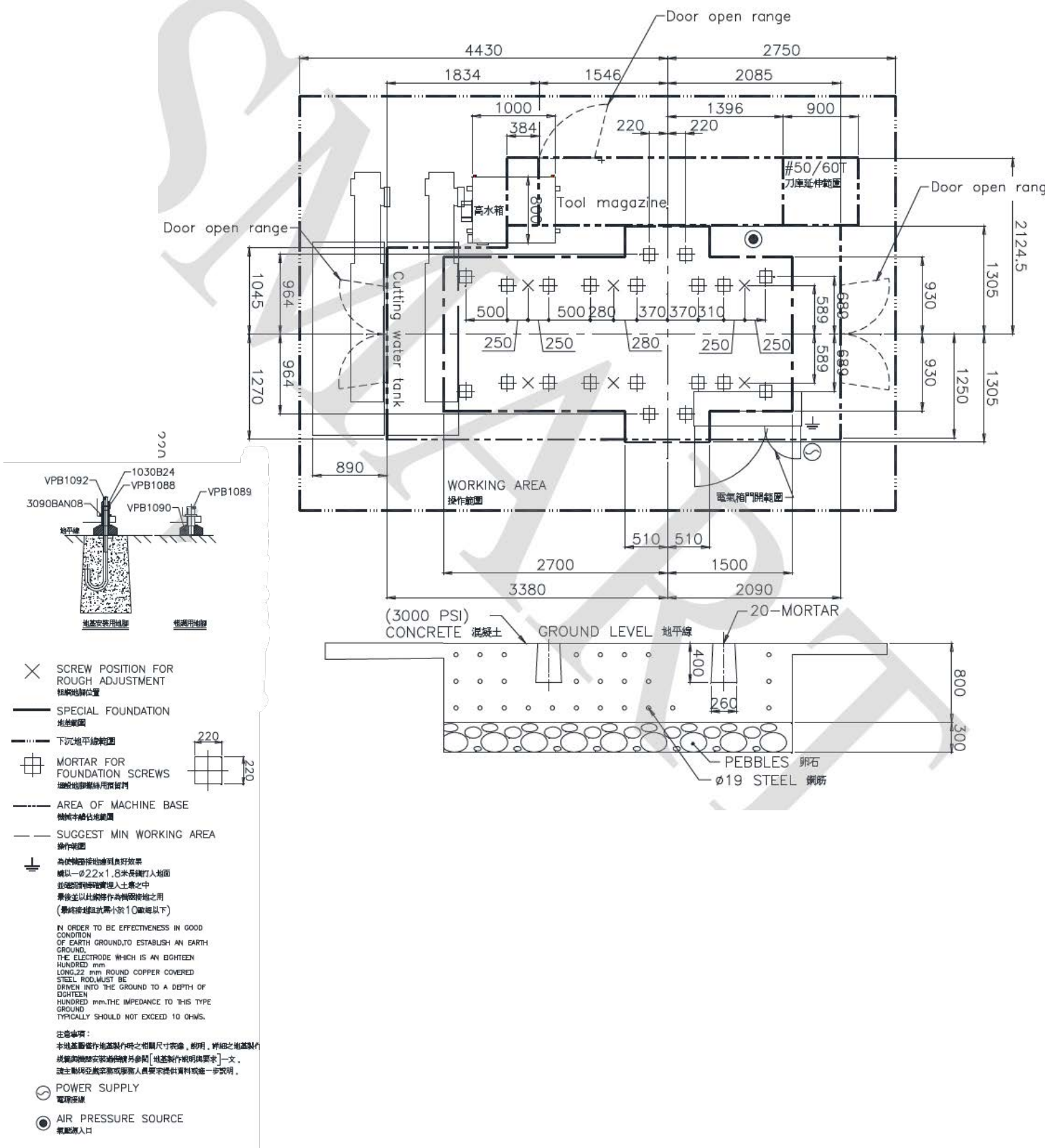

#40

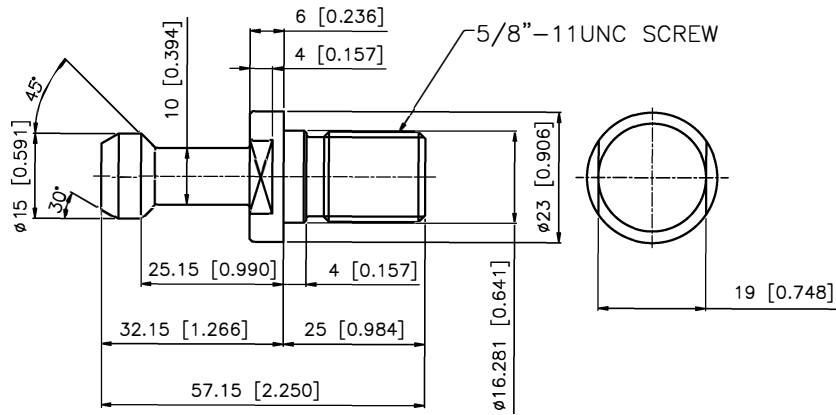

Lyndex PN
Non CTS
C40-4500
CTS
C40-4500H

#50

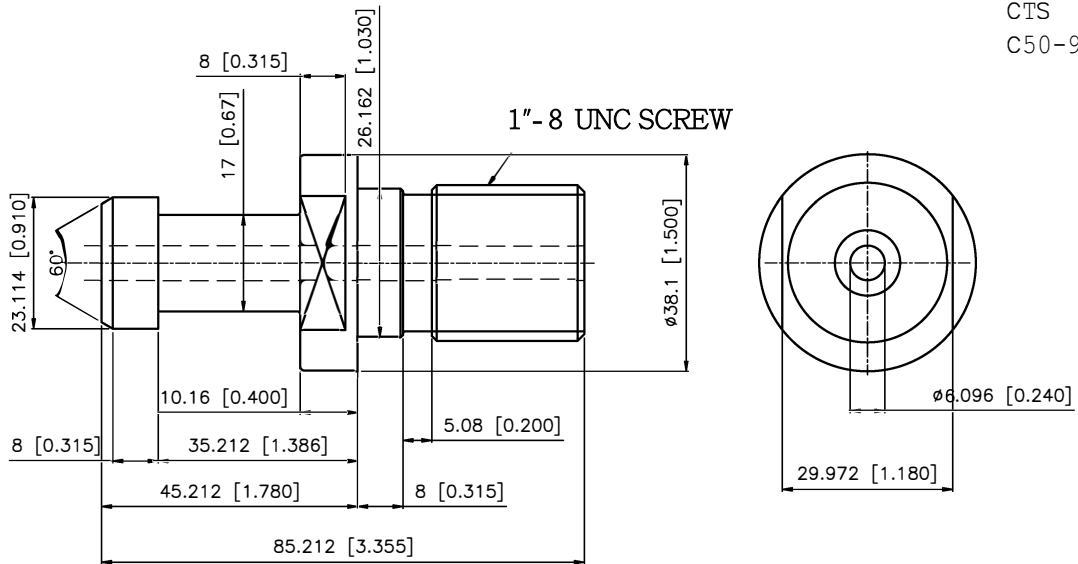

Lyndex PN
Non CTS
C50-9000
CTS
C50-9000H

Conestoga Trailers arranged by Walsh Logistics required for machine shipments

Model	Description	ESTIMATED PACKING	
		(Size - FT L x W x H)	(Size - LBS)
SM600 12K	MACHINE	11.25' x 7.6' x 8.4'	10,913
SM1000 12K	MACHINE	13x7.6x8.4'	12,513
SM965-24T	MACHINE	11'2 x 7'7 x 8'3	15,783
SM965-36T	MACHINE	16'1 X 7'7 X 8'2	15,783
SM965-36T	TOOL MAGAZINE	3'1 X 3'8 X 4'2	1,433
SM1165-24T	MACHINE	12'3 X 7'7 X 8'3	15,432
SM1165-36T	MACHINE	16'1 X 7'7 X 8'2	15,432
SM1165-36T	TOOL MAGAZINE	3'1 X 3'8 X 4'2	1,433
SM1165-30T	MACHINE	16'1 X 7'7 X 8'3	16,424
SM1165-30T	TOOL MAGAZINE	3'7 x 5'5 x 5'5	1,984
SM1365-36T	MACHINE	16'3 X 7'7 X 8'1	16,555
SM1365-36T	TOOL MAGAZINE	3'1 X 3'8 X 4'2	1,433
SM1365-30T	MACHINE	16'3 X 7'7 X 8'1	16,755
SM1365-30T	TOOL MAGAZINE	3'7 X 5'4 X 5'6	1,984
SM1565-36T	MACHINE	17'8 x 7'7 x 8'1	18,078
SM1565-36T	TOOL MAGAZINE	3'1 X 3'8 X 4'2	1,433
SM1565-30T	MACHINE	17'8 x 7'7 x 8'1	18,298
SM1565-30T	TOOL MAGAZINE	3'7 x 5'5 x 5'5	1,984
SM1575-36T	MACHINE	13.25'x7.6'x7.6'	19,000
SM1575-36T	TOOL MAGAZINE	3'7 x 5'5 x 5'5	1,984
SM1608	MACHINE & ACCESSORIES	17'9"x12'3"x3'78	39,000
SM1688	MACHINE & ACCESSORIES	17'9 X 13'6 X 11'3	42,064
SM2600	MACHINE	17'9"x13'2"x13'	47,399
SM2600	ACCESSORIES	18'1"x7'6"x6'5"	5,512
SM2600	ACCESSORIES	15'9"x7'6"x7'8"	7,716
SM850-APC	MACHINE	11'9 x 7'7 x 8'3	16,535
SM850-APC	ACCESSORIES(tool magazine, chip conveyor, etc.)	13' x 7'6 x 6'4	3,616
SM212	MACHINE & ACCESSORIES	18'10 x 12'4 x 12'2	39,551
SM312	MACHINE & ACCESSORIES	26'1 x 12'4 x 12'2	49,493

Conestoga not required for SM1688 and SM2600