

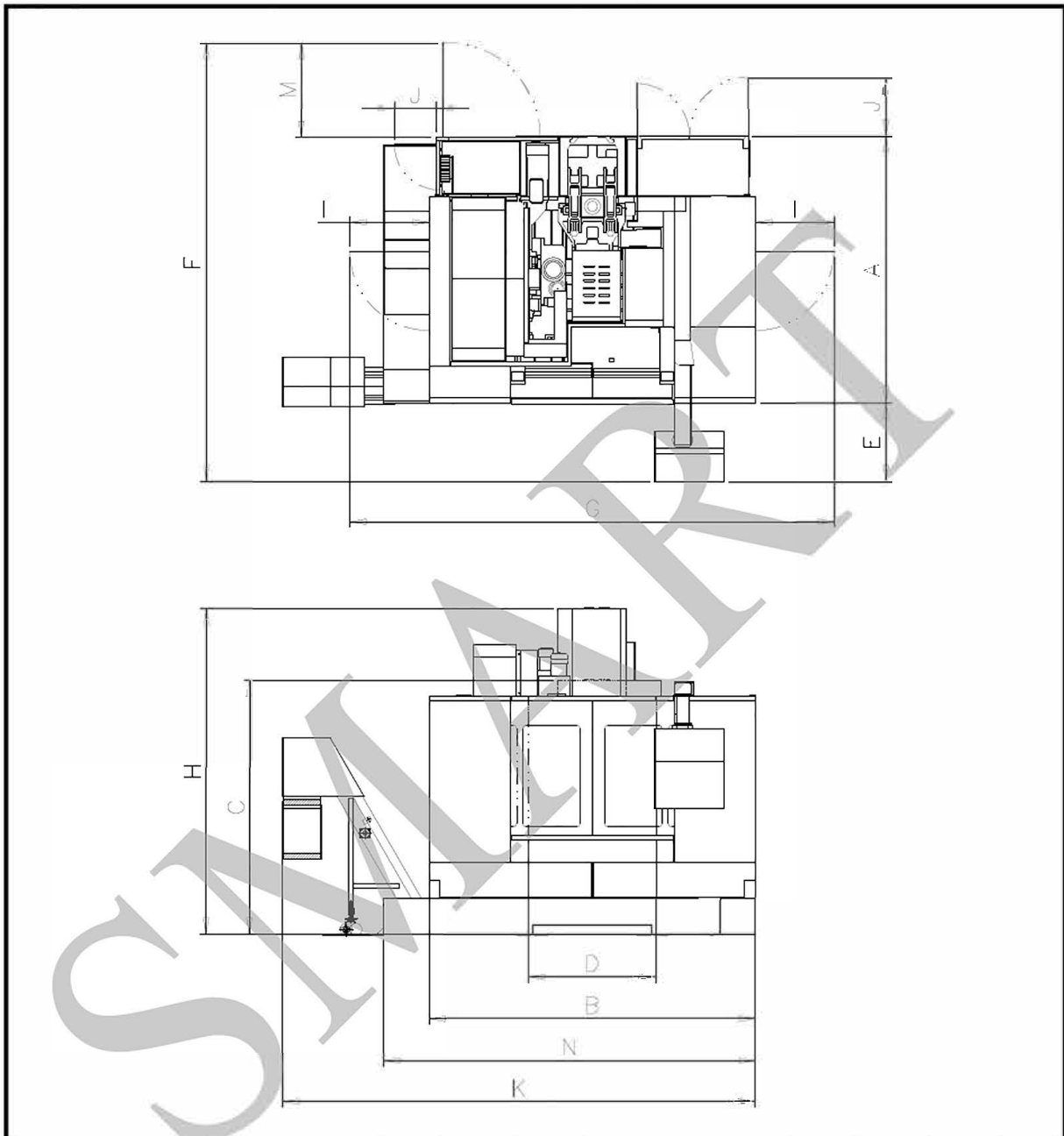

SM 1565

**Installation
Packet**

c. SM965/1165/1365/1565 36t CHIP CONVEYOR



Model	A	B	C	D	E	F	G	H	I	J	K	L	M	N
SM965	2,231	2,720	2,297	1,050	656	3,667	4,040	2,907	660	467	3,943	381	791	3,100
SM1165		3,170		1,270			4,490				4,393			3,434
SM1365		3,450		1,450			4,770				4,673			3,730
SM1565		3,850		1,620			5,170				5,073			4,130

d. SM1565

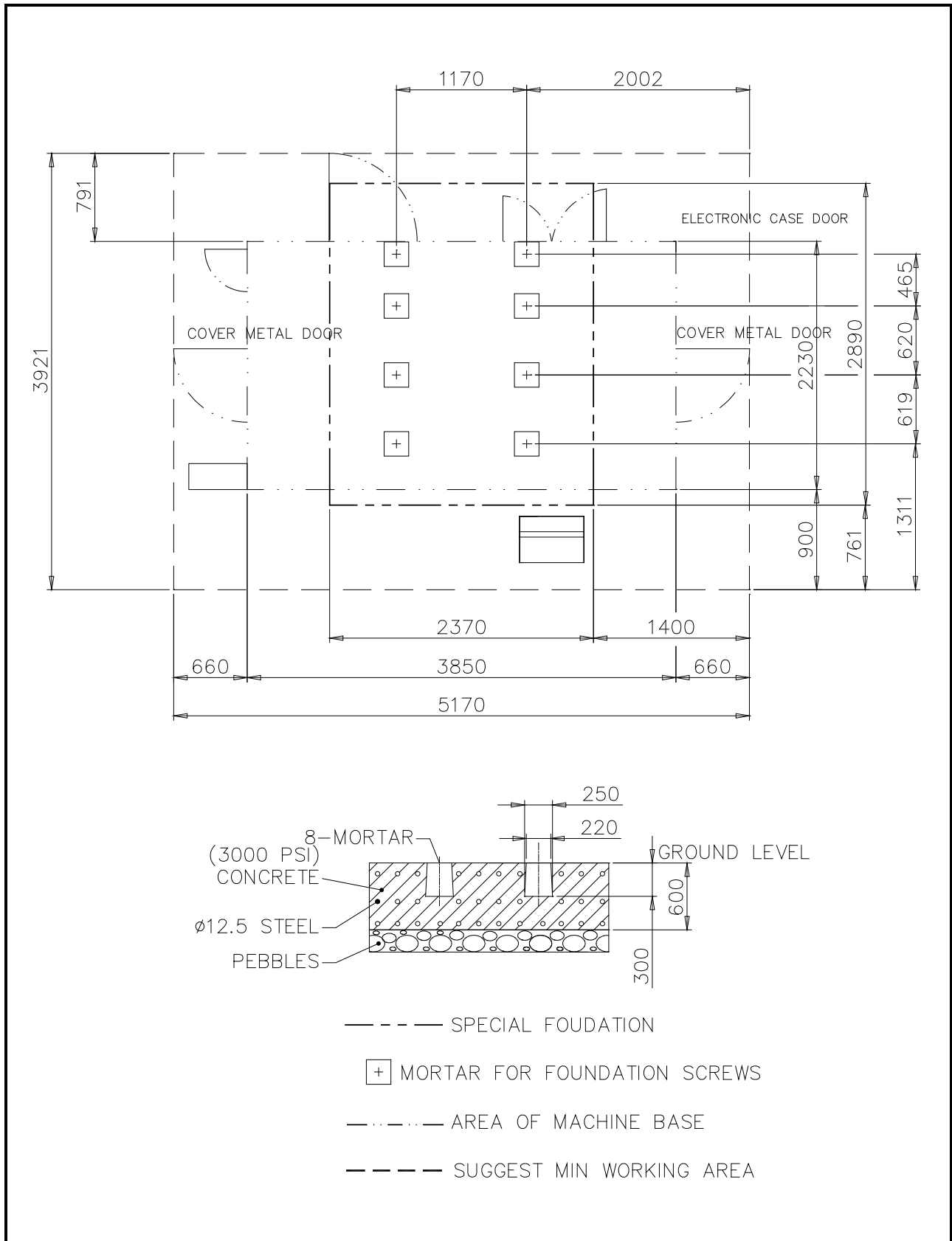

#40

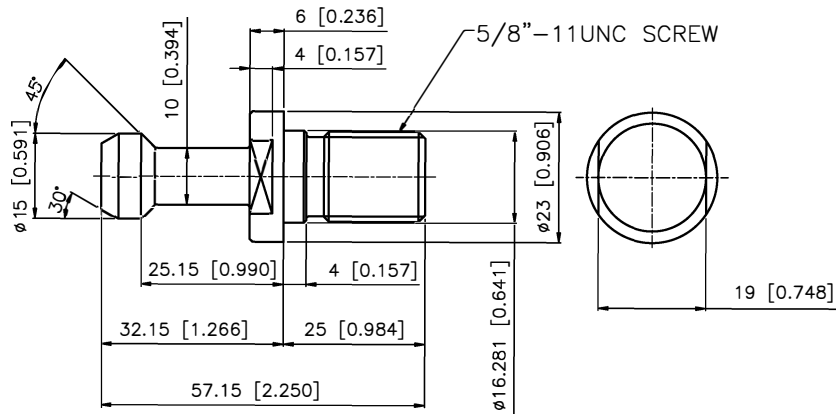

Lyndex PN
Non CTS
C40-4500
CTS
C40-4500H

#50

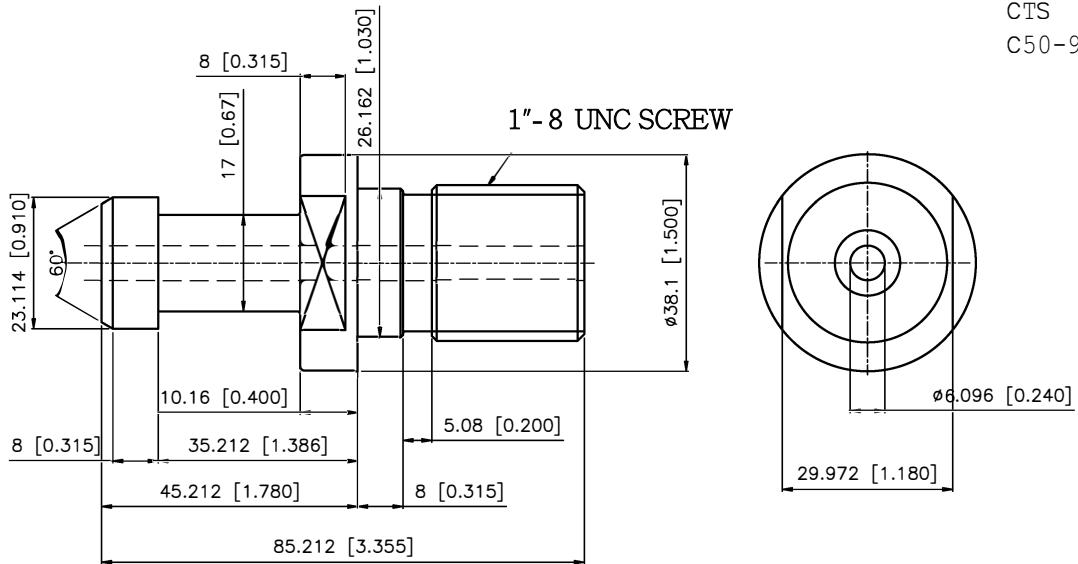

Lyndex PN
Non CTS
C50-9000
CTS
C50-9000H

POWER AND LUBRICATION REQUIREMENTS

10/1/2018 MACHINE MODEL	KVA	AMPS @ 220	Coolant	Slideways	Chilled Geared Headstock	Oil for Air	Chiller OilTank
SM850	25	65	87 gal	6L	N/A	6oz	20L
SM1000	25	65	89 gal	6L	N/A	6oz	20L
SM1688	45	118	116 gal	6L	20L	6oz	N/A
SM2600	50	131	360 gal	6L	20L	6oz	N/A
				Shell Tonna S3M68		Mobil DTE Light	Mobil Velocite #3
SM965 8K	25	65	95 gal	4.5L	1.2 gal	6oz	N/A
SM965 12K	40	104	95 gal	4.5L	N/A	6oz	20L
SM1165 8K	25	65	99 gal	4.5L	1.2 gal	6oz	N/A
SM1165 12K	40	104	99 gal	4.5L	N/A	6oz	20L
SM1165 6K	40	104	99 gal	4.5L	1.2 gal	6oz	N/A
SM1365 6K	40	104	103 gal	4.5L	1.2 gal	6oz	N/A
SM1365 12K	40	104	103 gal	4.5L	N/A	6oz	20L
SM1565 12K	40	104	105 gal	4.5L	N/A	6oz	20L
SM1565 6K	40	104	105 gal	4.5L	1.2 gal	6oz	N/A
				Shell Tonna S3M68	Mobil DTE 24	Mobil DTE Light	Mobil Velocite #6
				check daily	check daily	check daily	check daily

MCV Series:

Air: 8 CFM @ 80-100 PSI

Air Fitting Size: 5/8 DIA. MINIMUM ID

Conestoga Trailers arranged by Walsh Logistics required for machine shipments

Model	Description	ESTIMATED PACKING	
		(Size - FT L x W x H)	(Size - LBS)
SM600 12K	MACHINE	11.25' x 7.6' x 8.4'	10,913
SM1000 12K	MACHINE	13x7.6x8.4'	12,513
SM965-24T	MACHINE	11'2 x 7'7 x 8'3	15,783
SM965-36T	MACHINE	16'1 X 7'7 X 8'2	15,783
SM965-36T	TOOL MAGAZINE	3'1 X 3'8 X 4'2	1,433
SM1165-24T	MACHINE	12'3 X 7'7 X 8'3	15,432
SM1165-36T	MACHINE	16'1 X 7'7 X 8'2	15,432
SM1165-36T	TOOL MAGAZINE	3'1 X 3'8 X 4'2	1,433
SM1165-30T	MACHINE	16'1 X 7'7 X 8'3	16,424
SM1165-30T	TOOL MAGAZINE	3'7 x 5'5 x 5'5	1,984
SM1365-36T	MACHINE	16'3 X 7'7 X 8'1	16,555
SM1365-36T	TOOL MAGAZINE	3'1 X 3'8 X 4'2	1,433
SM1365-30T	MACHINE	16'3 X 7'7 X 8'1	16,755
SM1365-30T	TOOL MAGAZINE	3'7 X 5'4 X 5'6	1,984
SM1565-36T	MACHINE	17'8 x 7'7 x 8'1	18,078
SM1565-36T	TOOL MAGAZINE	3'1 X 3'8 X 4'2	1,433
SM1565-30T	MACHINE	17'8 x 7'7 x 8'1	18,298
SM1565-30T	TOOL MAGAZINE	3'7 x 5'5 x 5'5	1,984
SM1575-36T	MACHINE	13.25'x7.6'x7.6'	19,000
SM1575-36T	TOOL MAGAZINE	3'7 x 5'5 x 5'5	1,984
SM1608	MACHINE & ACCESSORIES	17'9"x12'3"x3'78	39,000
SM1688	MACHINE & ACCESSORIES	17'9 X 13'6 X 11'3	42,064
SM2600	MACHINE	17'9"x13'2"x13'	47,399
SM2600	ACCESSORIES	18'1"x7'6"x6'5"	5,512
SM2600	ACCESSORIES	15'9"x7'6"x7'8"	7,716
SM850-APC	MACHINE	11'9 x 7'7 x 8'3	16,535
SM850-APC	ACCESSORIES(tool magazine, chip conveyor, etc.)	13' x 7'6 x 6'4	3,616
SM212	MACHINE & ACCESSORIES	18'10 x 12'4 x 12'2	39,551
SM312	MACHINE & ACCESSORIES	26'1 x 12'4 x 12'2	49,493

Conestoga not required for SM1688 and SM2600