

**SMART**  
MACHINE TOOL

**NL 200**

**Installation  
Packet**

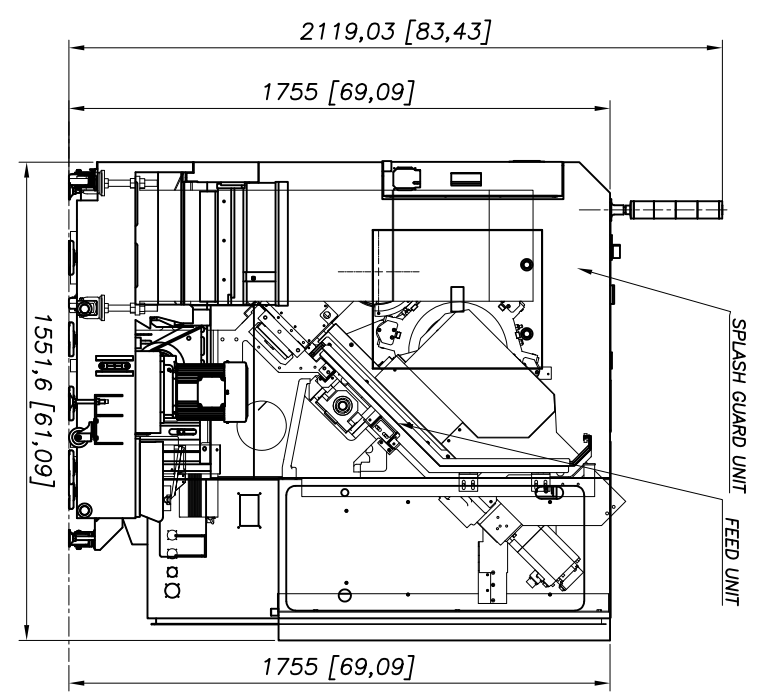
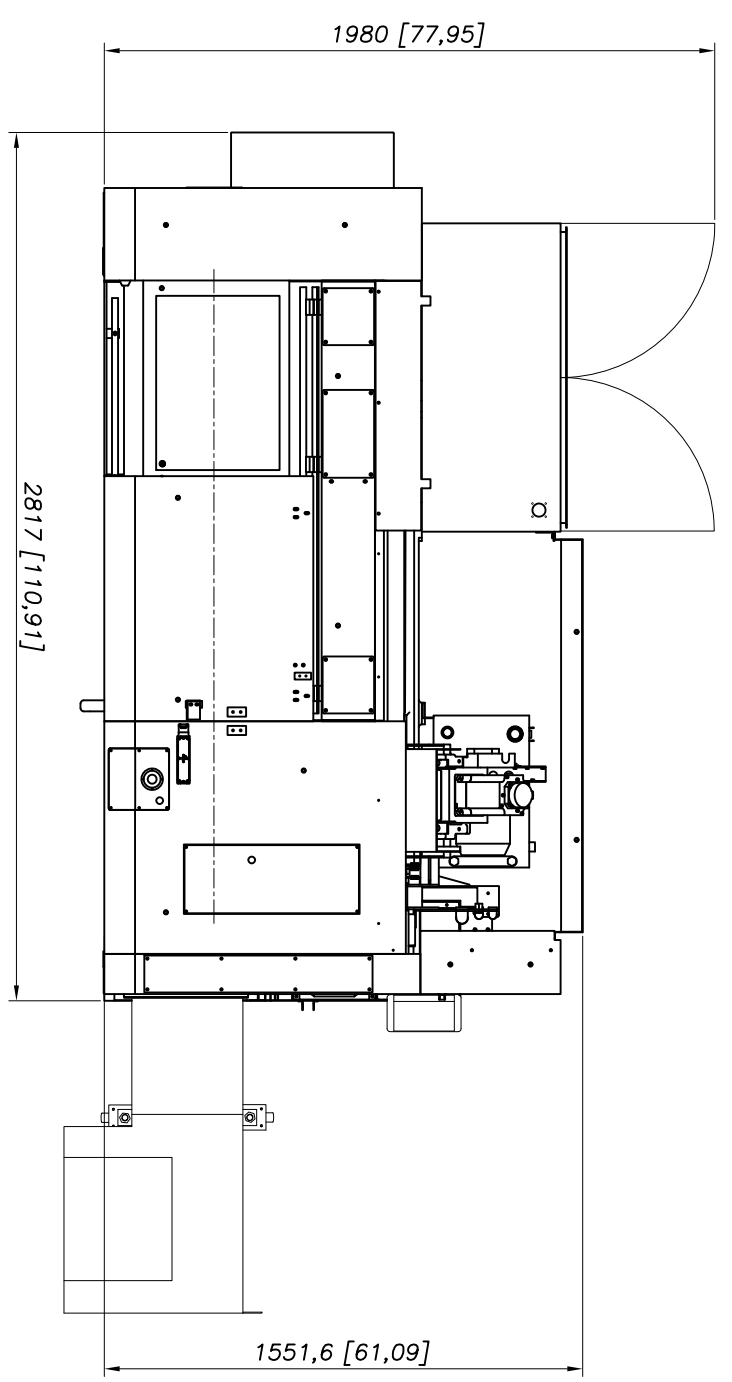
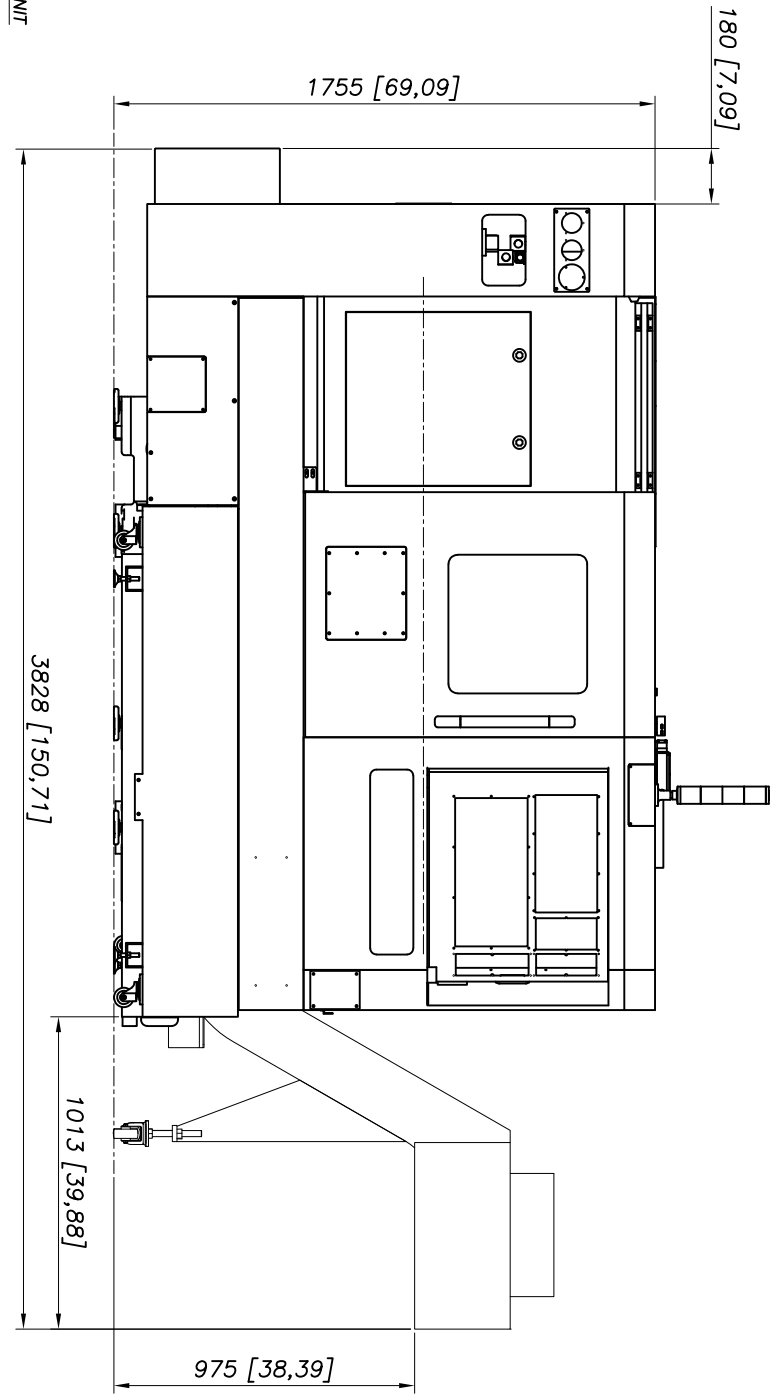
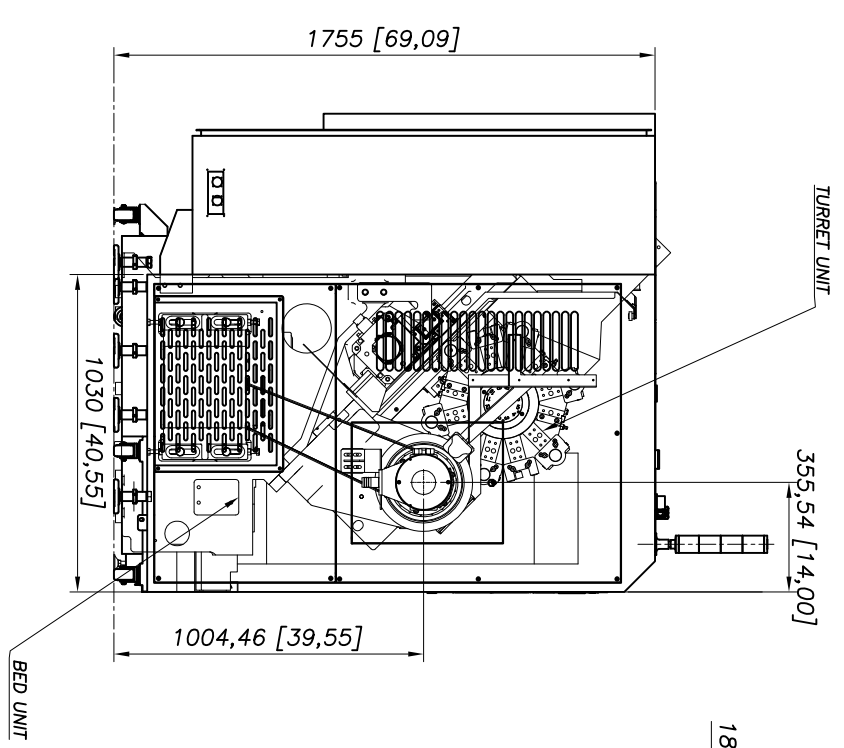

MARK	REVISION	DATE	REV'D	CHE'D	DES'D	APP'D	GENERAL TOLERANCE	HEAT TREATMENT	UNIT ASS'Y	SCALE	NAME
							0.3 - 6 ± 0.1		SMTK	1/1	N2100004A00
							6 - 30 ± 0.2		LAY-OUT	1/1	GENERAL ASS'Y
							30 - 120 ± 0.3		NL200/250		
							120 - 315 ± 0.5				
							315 - 1000 ± 0.8				
							1000 - 2000 ± 1.2				
							2000 - 5000 ± 1.5				
							5000 - 10000 ± 2.0				
							10000 - 20000 ± 3.0				
							20000 - 50000 ± 4.0				
							50000 - 100000 ± 5.0				
							100000 - 200000 ± 6.0				
							200000 - 500000 ± 8.0				
							500000 - 1000000 ± 10.0				
							1000000 - 2000000 ± 12.0				
							2000000 - 5000000 ± 15.0				
							5000000 - 10000000 ± 18.0				
							10000000 - 20000000 ± 20.0				
							20000000 - 50000000 ± 22.0				
							50000000 - 100000000 ± 25.0				
							100000000 - 200000000 ± 28.0				
							200000000 - 500000000 ± 30.0				
							500000000 - 1000000000 ± 32.0				
							1000000000 - 2000000000 ± 35.0				
							2000000000 - 5000000000 ± 38.0				
							5000000000 - 10000000000 ± 40.0				
							10000000000 - 20000000000 ± 42.0				
							20000000000 - 50000000000 ± 45.0				
							50000000000 - 100000000000 ± 48.0				
							100000000000 - 200000000000 ± 50.0				
							200000000000 - 500000000000 ± 52.0				
							500000000000 - 1000000000000 ± 55.0				
							1000000000000 - 2000000000000 ± 58.0				
							2000000000000 - 5000000000000 ± 60.0				
							5000000000000 - 10000000000000 ± 62.0				
							10000000000000 - 20000000000000 ± 65.0				
							20000000000000 - 50000000000000 ± 68.0				
							50000000000000 - 100000000000000 ± 70.0				
							100000000000000 - 200000000000000 ± 72.0				
							200000000000000 - 500000000000000 ± 75.0				
							500000000000000 - 1000000000000000 ± 78.0				
							1000000000000000 - 2000000000000000 ± 80.0				
							2000000000000000 - 5000000000000000 ± 82.0				
							5000000000000000 - 10000000000000000 ± 85.0				
							10000000000000000 - 20000000000000000 ± 88.0				
							20000000000000000 - 50000000000000000 ± 90.0				
							50000000000000000 - 100000000000000000 ± 92.0				
							100000000000000000 - 200000000000000000 ± 95.0				
							200000000000000000 - 500000000000000000 ± 98.0				
							500000000000000000 - 1000000000000000000 ± 100.0				

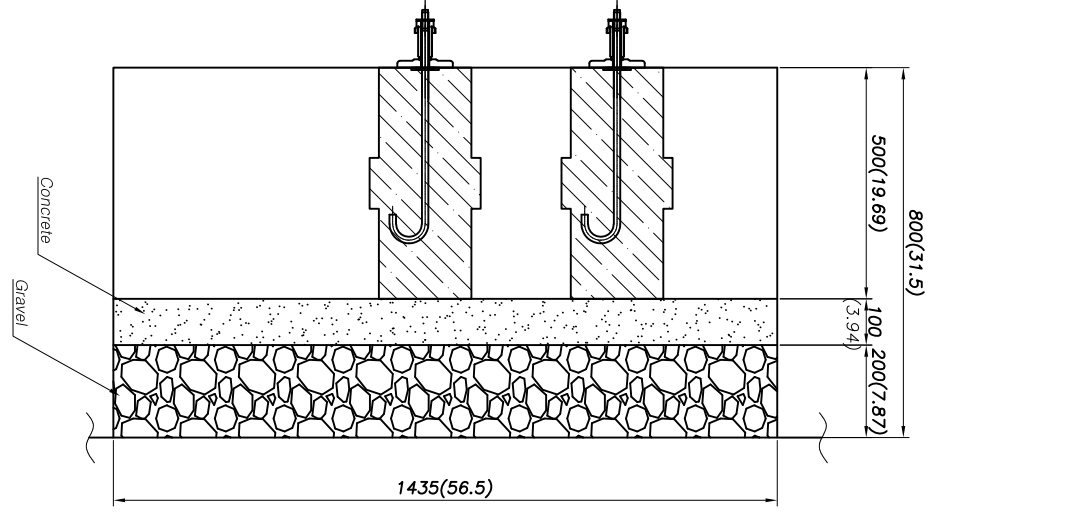
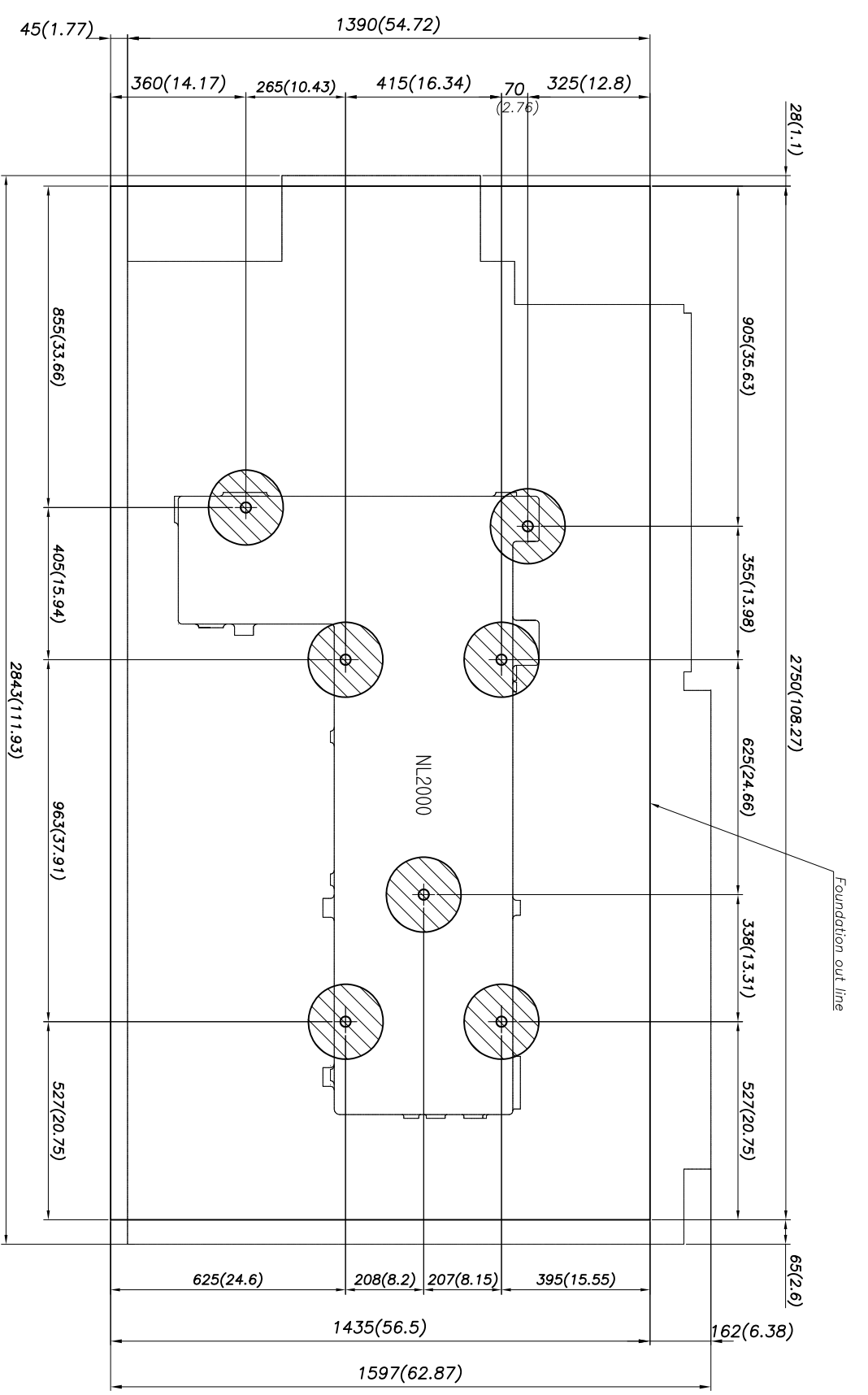

Note1) This drawing shows the standard foundation.  
Modify the concrete thickness according to ground condition.

Before the first concrete is completely dry, chamfer the area facing the outside of the machine by approximately 100 mm.

Concrete strength (28 days after placing concrete) should be 20.6 Mpa(2986.2 psi) or more.

Note2) Because 100 mm(3.94 inch) of styrofoam must adhere to the inside surface of ditch, dig the foundation 100 mm(3.94 inch) outside of the outline of the foundation.

Note3) Unit : mm(inch)

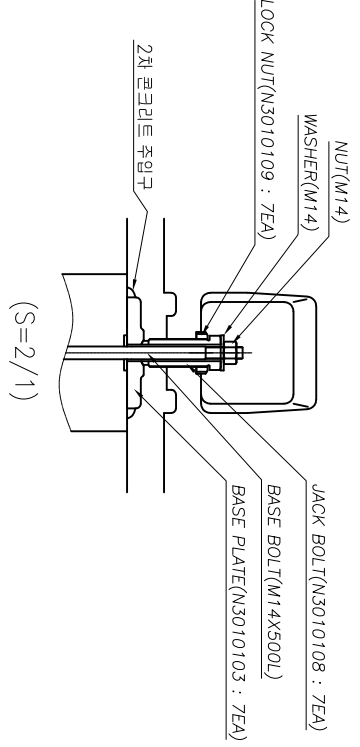
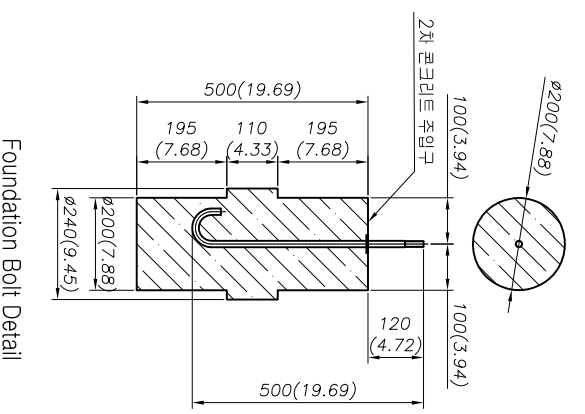

MARK	REVISION	DATE	REV'D	CHE'D	DATE	REV'D	CHE'D	DATE	REV'D	CHE'D	DATE	REV'D	CHE'D

APP'D	DES'D	NAME	UNIT ASS'Y
		NL2000	LAY-OUT

GENERAL	TOLERANCE	HEAT TREATMENT	SMTK
0.5- 6 ± 0.1			
6- 30 ± 0.2			
30- 120 ± 0.3			
120- 315 ± 0.5			
315- 1000 ± 0.8			
1000- 2000 ± 1.2			
2000- 5000 ± 2.0			

DESIGNER	CHECKER	SCALE	NAME
		1/8	FOUNDATION ASS'Y

MARK	REVISION	DATE	REV'D	CHE'D	DATE	REV'D	CHE'D	DATE	REV'D	CHE'D

MACHINE MODEL	KVA	AMPS @ 220	Coolant	Slideways	Hyd. Unit	Transmission	Chuck	Oil for Air
NL150/200/250	31	82	48	.79 gal	5.3 gal	n/a	.2 oz daily	N/A
NL2000(M)	31	82	48	.79 gal	5.3 gal	n/a	.2 oz daily	.6 oz
NL2500(M)	40	105	53	.79 gal	5.3 gal	0.75	.2 oz daily	.6 oz
NL3000(M)	40	105	63	.79 gal	5.3 gal	0.75	.2 oz daily	N/A
NL4000(M)	55	144	63	.79 gal	6.4 gal	0.75	.2 oz daily	N/A
NL5000(M)	55	144	63	.79 gal	6.4 gal	0.75	.2 oz daily	N/A
NL5000L(M)	65	170	130	.79 gal	6.4 gal	0.75	.2 oz daily	N/A
NL6000(M)	65	170	105	.79 gal	15 gal	0.75	.2 oz daily	N/A
NL6000L(M)	65	170	150	.79 gal	15 gal	0.75	.2 oz daily	N/A
NL6000XL(M)	65	170	180	.79 gal	15 gal	0.75	.2 oz daily	
NL7000L(M)	65	170	150	.79 gal	15 gal	2 gal	.2 oz daily	N/A
NL7000XL(M)	65	170	180	.79 gal	15 gal	2 gal	.2 oz daily	N/A
				Shell Oil T68	Mobil DTE	Mobil Oil Light		DTE Light
				Mobil Vactra#	24	ISO VG 32	grease daily	check daily
				check daily	check daily	check daily		

Conestoga Trailers arranged by Walsh Logistics required for all machine shipments

Model	Description	ESTIMATED PACKING	
		(Size - FEET)	(Size - LBS)
NL150/200/250	MACHINE + CONVEYOR	13x7.5x7.5	10,500
NL2000(M)(B)	MACHINE + CONVEYOR	13x7.5x7.5	10,500
NL2000SY	MACHINE + CONVEYOR	17.5 x 7.6 x 8.1	14,330
NL2500(M)	MACHINE + CONVEYOR	16.7x7.6x7.4	13,900
NL3000(M)	MACHINE + CONVEYOR	16.7x7.6x7.4	14,500
NL3000L(M)	MACHINE + CONVEYOR	19.5x7.6x7.4	16,800
NL4000(M)	MACHINE	16x7.5x8	25,000
NL4000(M)	CHIP CONVEYOR	14x3.1x5	1,925
NL5000(M)	MACHINE	16x7.5x8	25,500
NL5000(M)	CHIP CONVEYOR	14x3.1x5	1,925
NL5000L(M)	MACHINE	20x7.5x8	32,000
NL5000L(M)	CHIP CONVEYOR	18x3.1x5	2,500
NL6000(M)	MACHINE	18.7x7.5x8.4	35,250
NL6000(M)	CHIP CONVEYOR	15.9x7.5x5.75	2,350
NL6000L(M)	MACHINE	21x7.5x8.5	40,000
NL6000L(M)	CHIP CONVEYOR	18.2x7.5x5.75	4,000
NL6000XL(M)	MACHINE	26x7.5x8.5	50,000
NL6000XL(M)	CHIP CONVEYOR	22.5x7.5x5.75	5,500
NL7000L(M)	MACHINE		
NL7000XL(M)	MACHINE		

