

SMART
MACHINE TOOL

VX350

**Installation
Packet**

B. Floor Space**1-1 K-700FX/K-35 5AX/K-25 5AX**

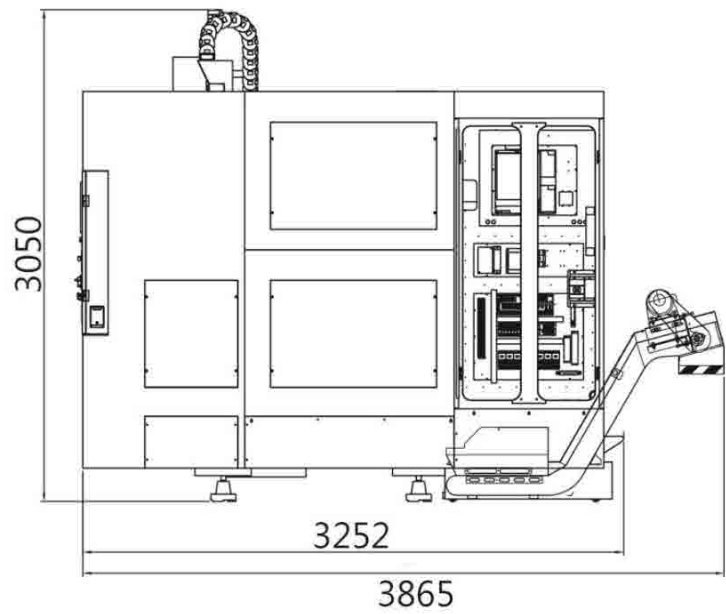
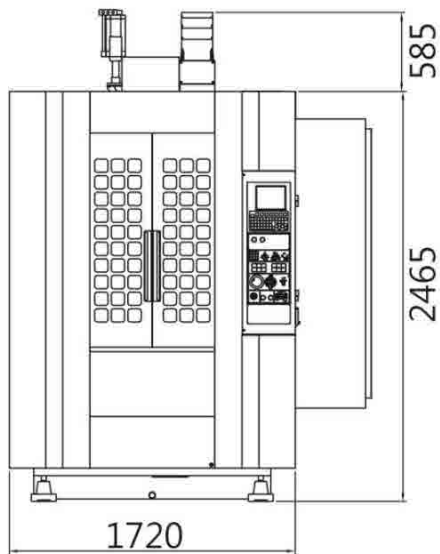
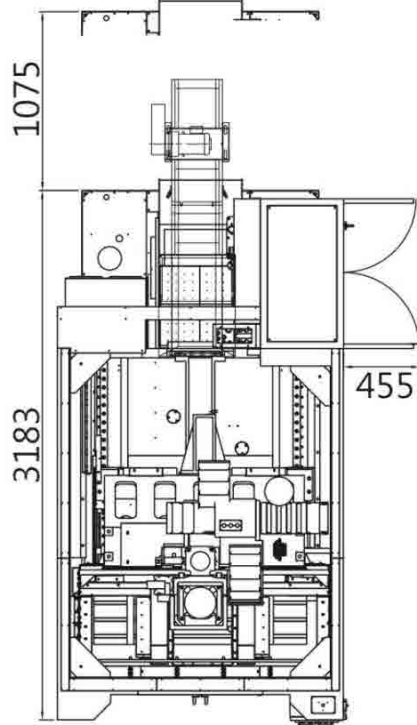
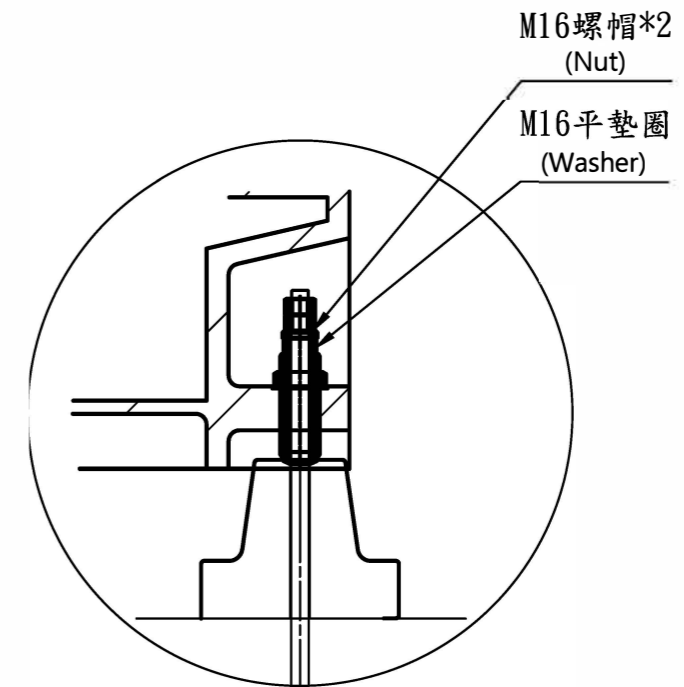
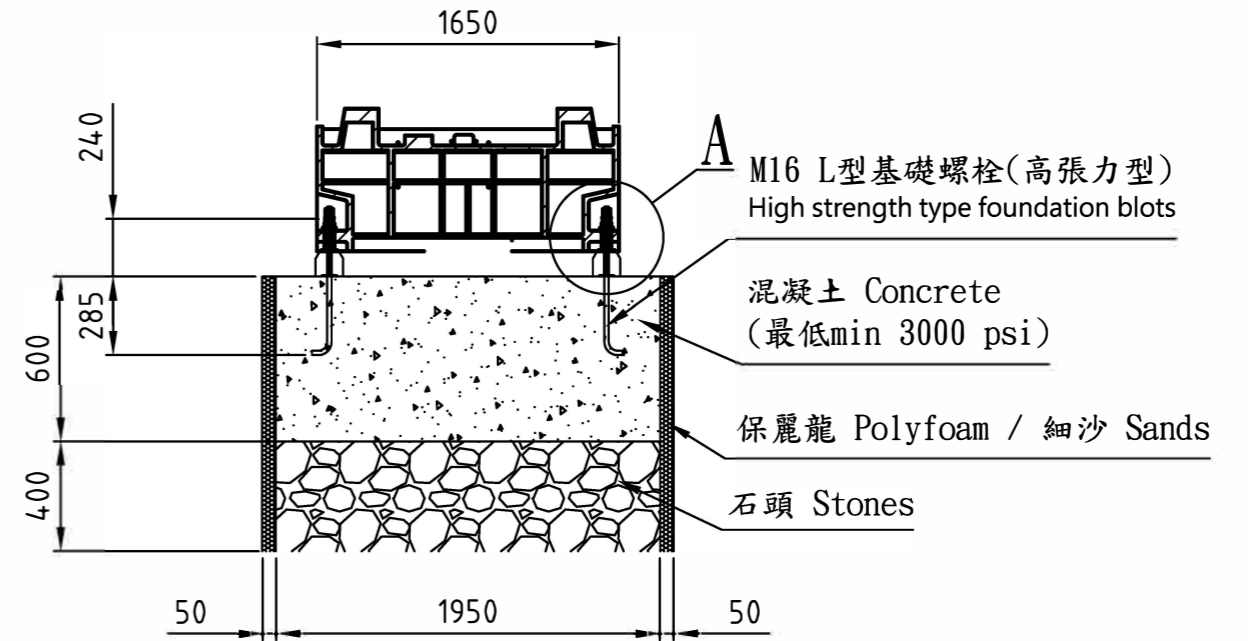
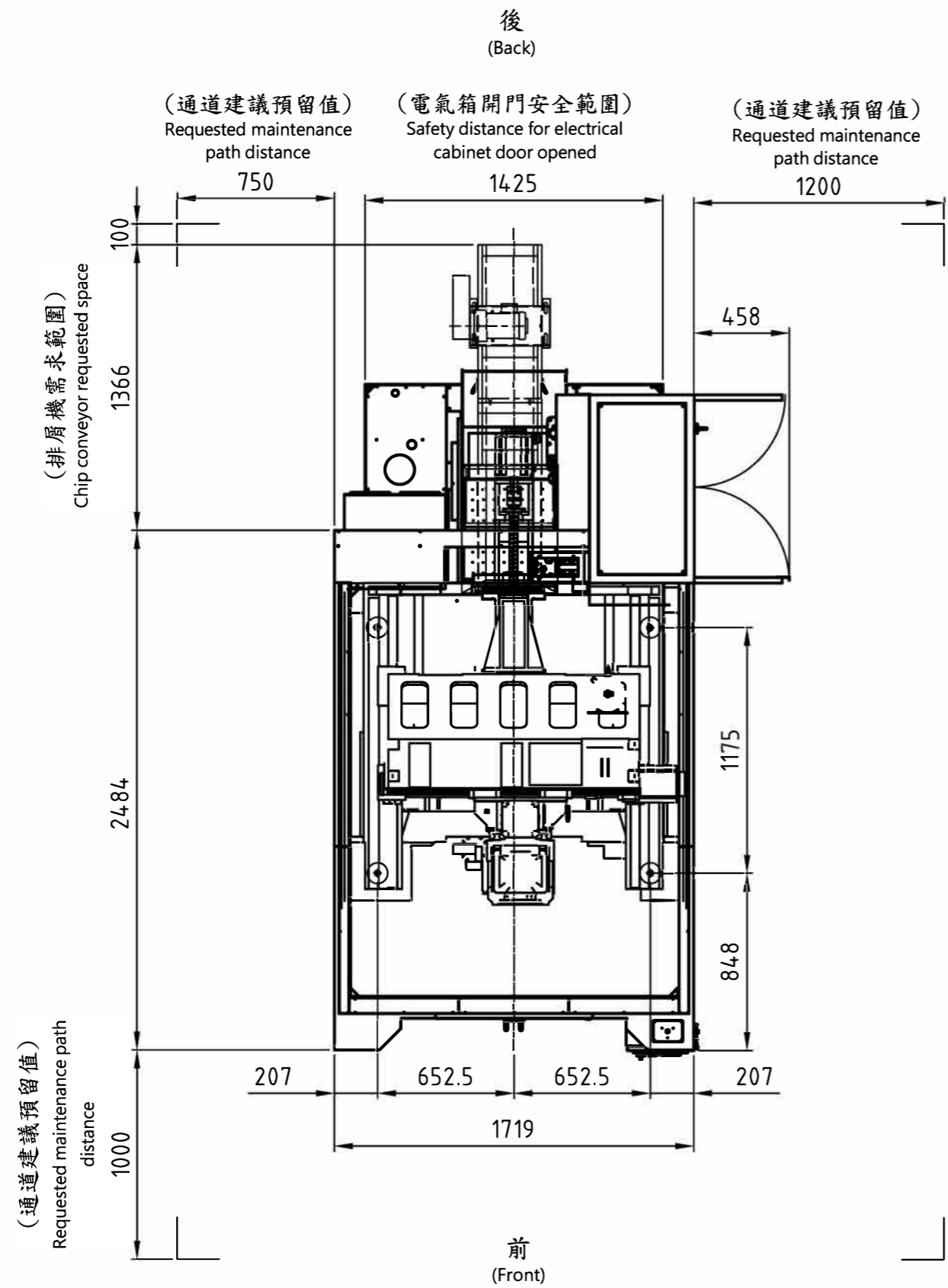

細部放大視圖 A

※機台安全工作高度為3200mm
(Machine safety installation height 3200mm)

#40

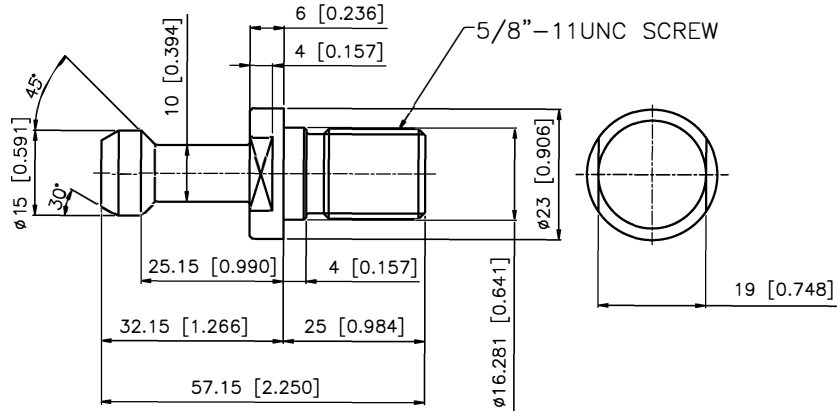

#50

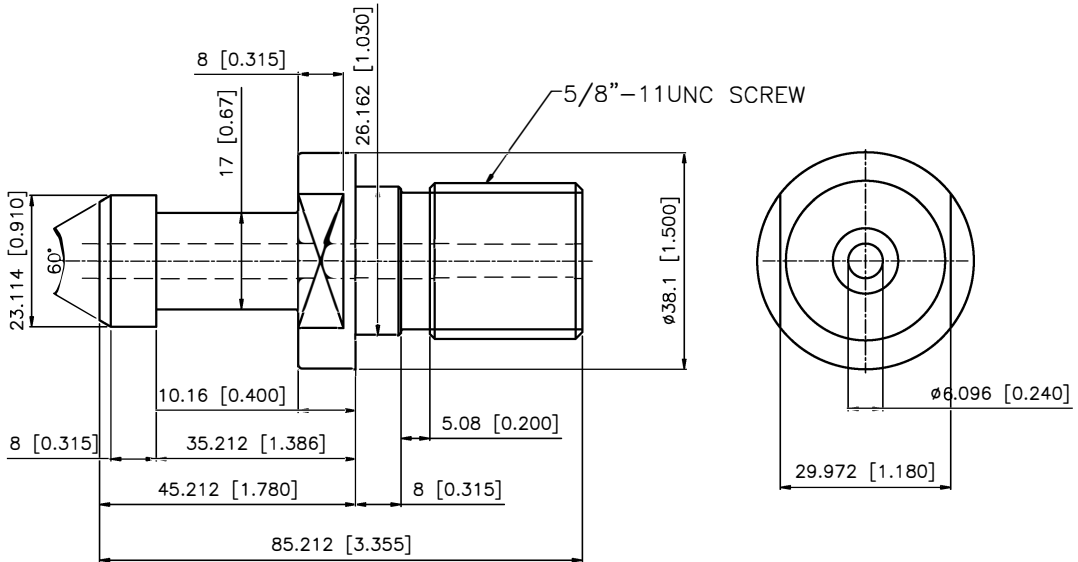

SMART MACHINE TOOL

VX350 Shipping Dimensions	
Length	14 ft
Wide	7.6 ft
Height	8.4 ft
Weight	15,652 lbs

RECOMMENDED LUBRICATION & COOLANT TABLE

PART	CAPACITY	RECOMMENDED LUBRICATION/COOLANT	TIME TO CHECK OUT	REMARK
Transmission system (Lubricating oil)	2 L	ISO VG68	Should be checked daily. Should be appended immediately when the level is low.	Should check the lubrication system immediately when there is no lubrication consuming
Transmission system (Cartridge grease)	0.7 L	LHL-X100		
Coolant (For cutting)	200L	According to the parts material you want to machine	Should be checked daily Should be appended immediately when the level is low	Please clean the tank filter weekly.
Pneumatic system	50 mL	ISO VG3	Should be checked daily Should be appended immediately when the level is low	According to the machine model. Some models without this lubrication
Spindle Chiller	20 L	ISO VG10	Should be checked daily Should be appended immediately when the level is low	Should be renewed per year.
Hydraulic system	Refer to machine model	ISO VG32	Should be checked daily Should be appended immediately when the level is low	Should be renewed per year.
Rotary table fourth or fifth	Refer to the model of rotary table	ISO VG100	Should be checked monthly	Should be renewed per year.
ATC (Arm type)	7L	ISO VG200	Should be checked monthly	Should be renewed per year.