

SMART
MACHINE TOOL

SM 212/312

**Installation
Packet**

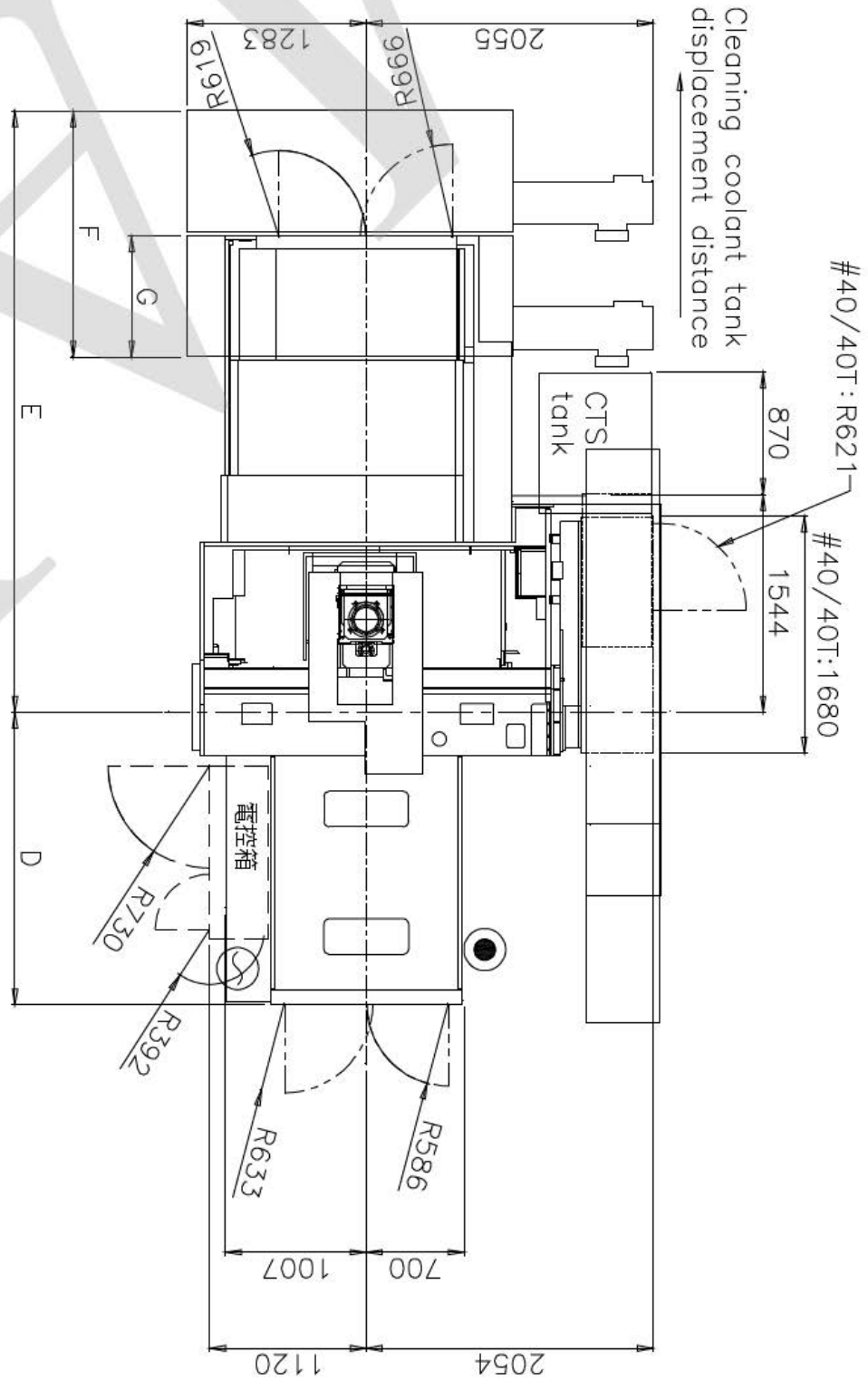

Unit : mm

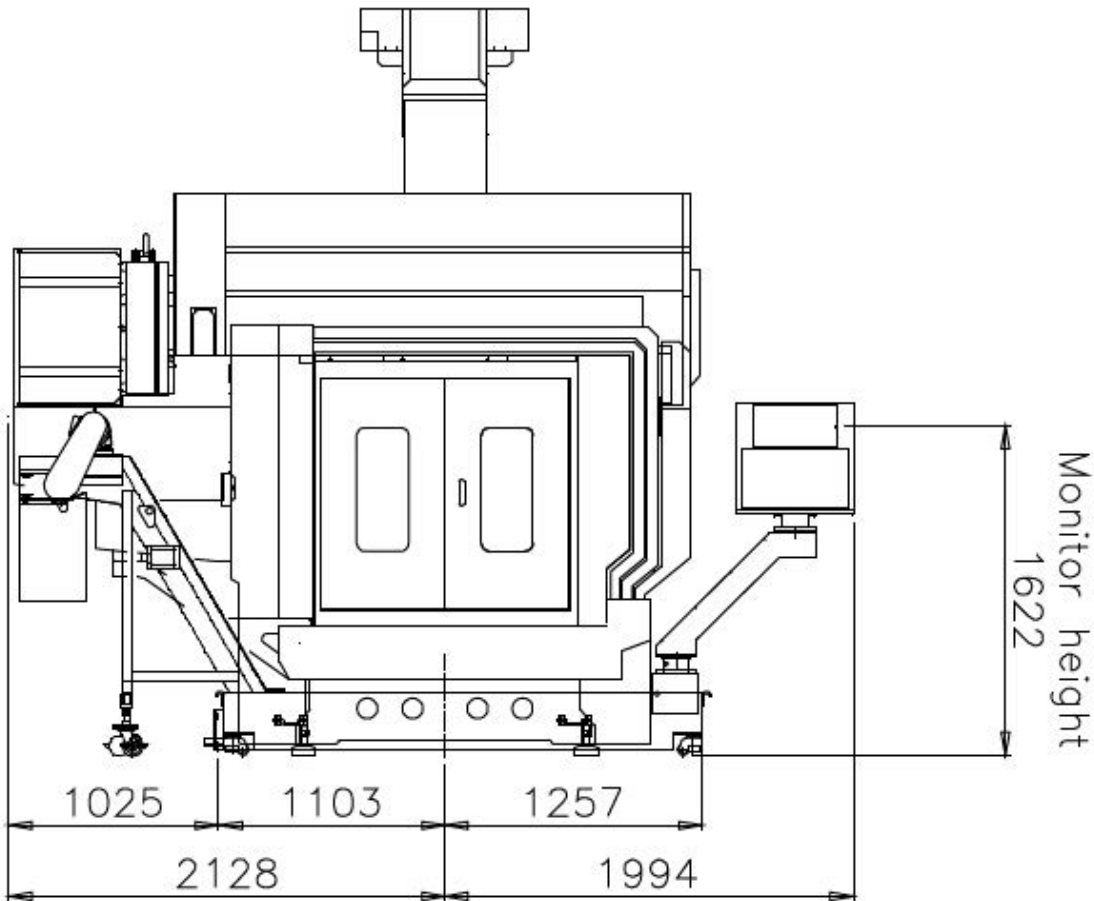
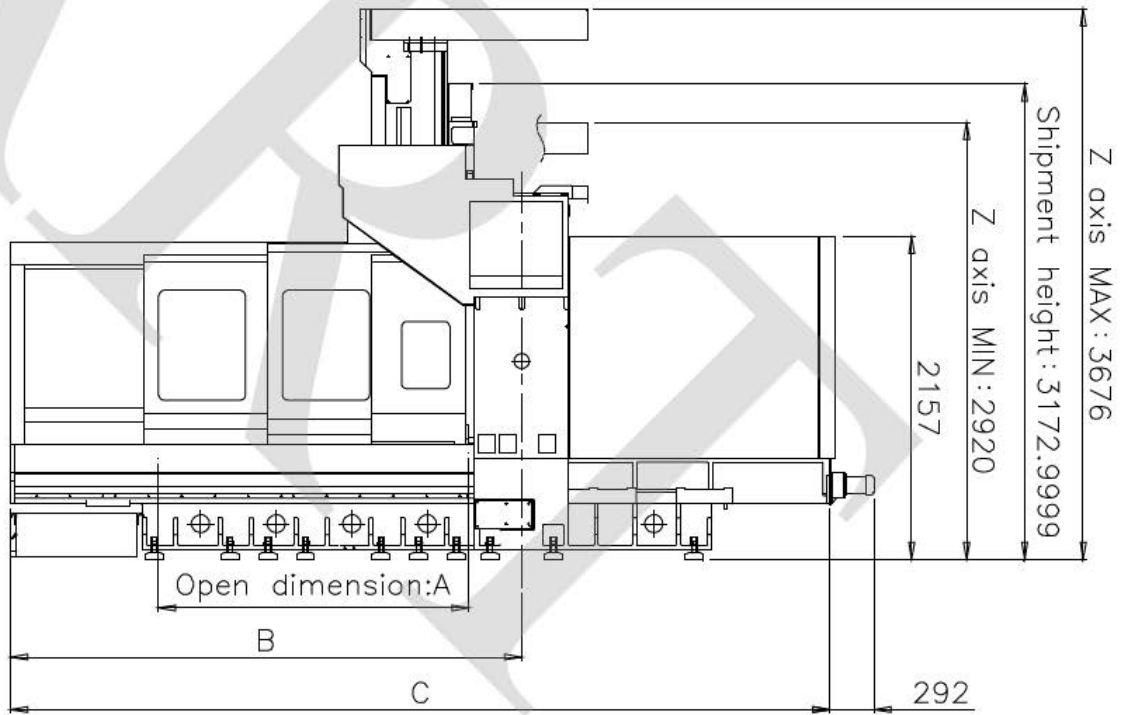

(Unit : mm)

Size	Type	SM212	SM312
A		2057	3060
B		3383	4381
C		5425	7425
D		2082	3082
E		4270	5302
F		860	860
G		1750	1750

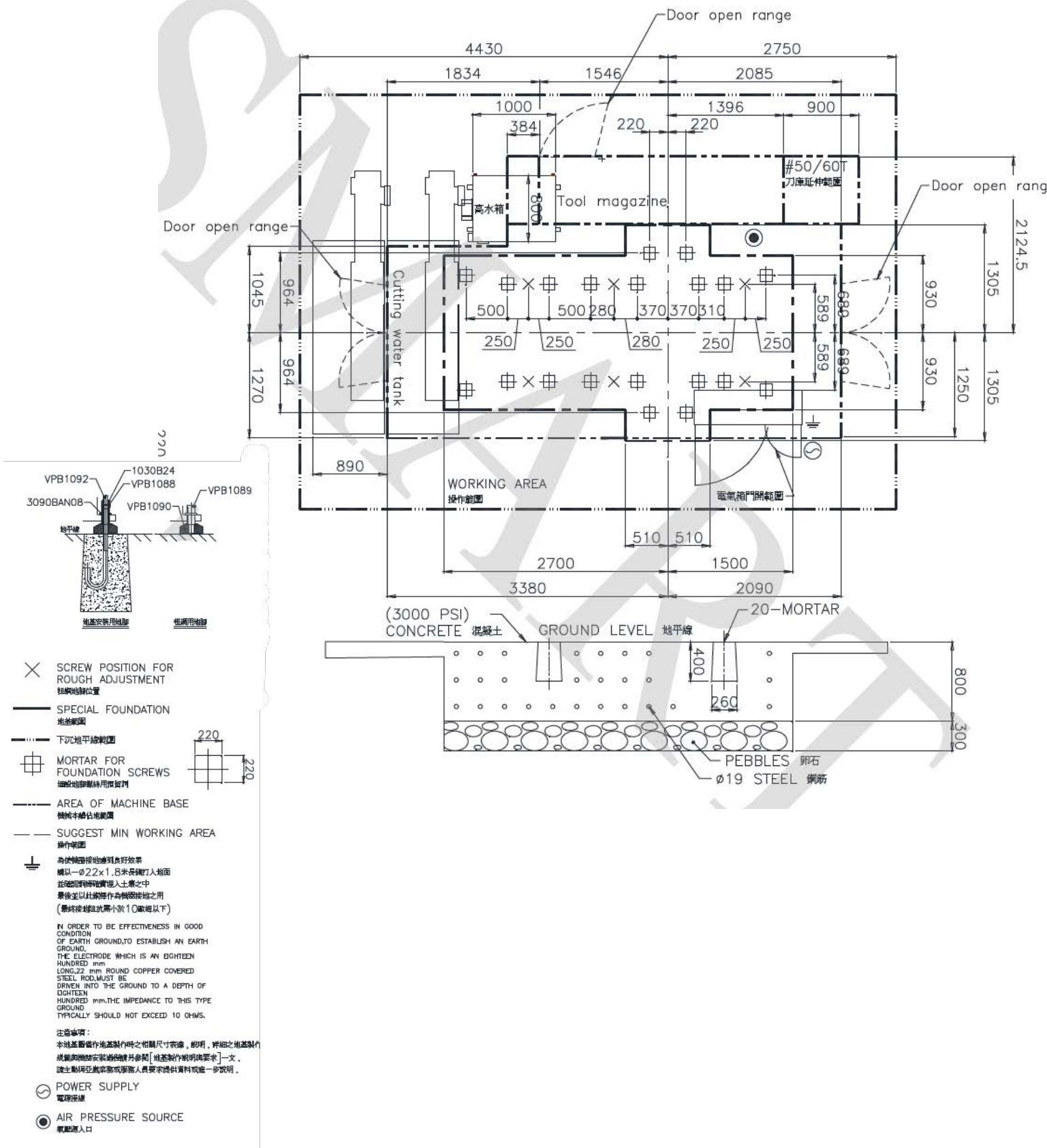

#40

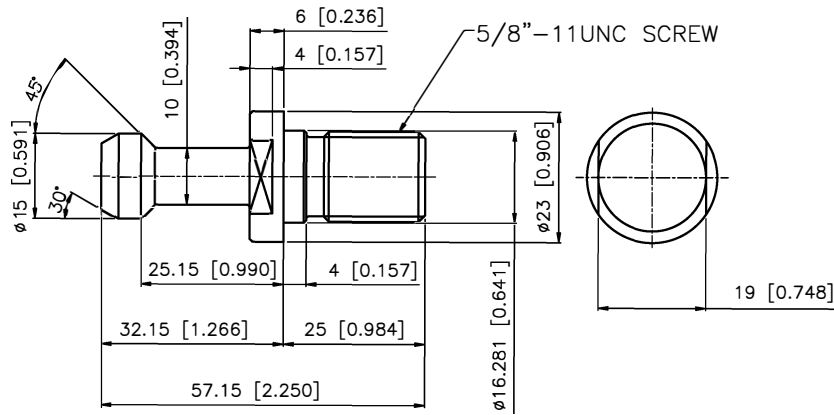

Lyndex PN
Non CTS
C40-4500
CTS
C40-4500H

#50

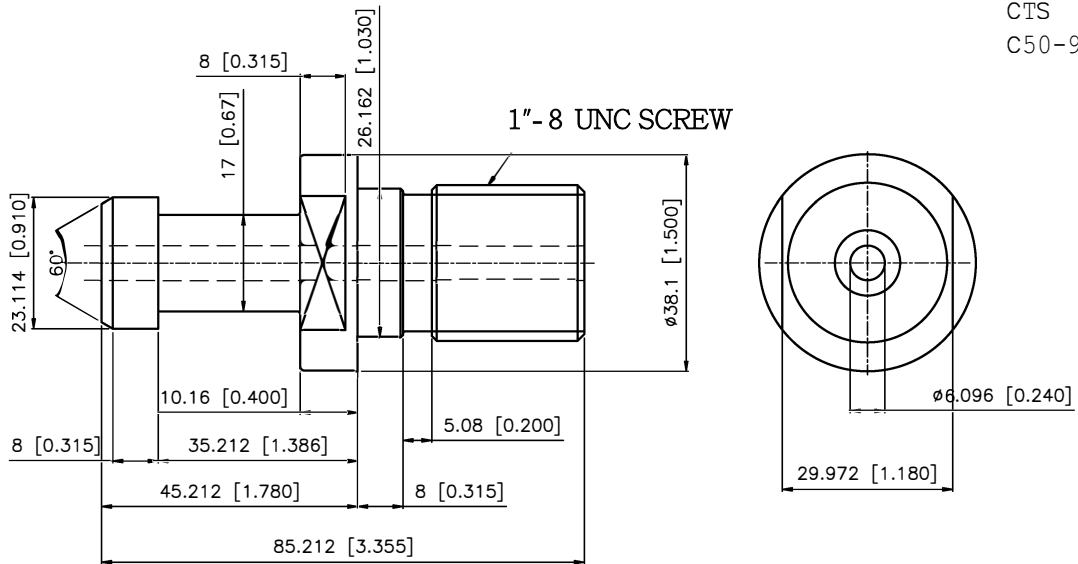

Lyndex PN
Non CTS
C50-9000
CTS
C50-9000H

POWER AND LUBRICATION REQUIREMENTS

10/1/2018 MACHINE MODEL	KVA	AMPS @ 220	Coolant	Slideways	Chilled Gearing Headstock	Oil for Air	Chiller OilTank
SM850	25	65	87 gal	6L	N/A	6oz	20L
SM1000	25	65	89 gal	6L	N/A	6oz	20L
SM1688	45	118	116 gal	6L	20L	6oz	N/A
SM2600	50	131	360 gal	6L	20L	6oz	N/A
				Shell Tonna S3M68		Mobil DTE Light	Mobil Velocite #3
SM600	25	65	85 gal	4.5L	N/A	6oz	20L
SM1000	25	65	85 gal	4.5L	N/A	6oz	20L
SM965 8K	25	65	95 gal	4.5L	1.2 gal	6oz	N/A
SM965 12K	40	104	95 gal	4.5L	N/A	6oz	20L
SM1165 8K	25	65	99 gal	4.5L	1.2 gal	6oz	N/A
SM1165 12K	40	104	99 gal	4.5L	N/A	6oz	20L
SM1165 6K	40	104	99 gal	4.5L	1.2 gal	6oz	N/A
SM1365 6K	40	104	103 gal	4.5L	1.2 gal	6oz	N/A
SM1365 12K	40	104	103 gal	4.5L	N/A	6oz	20L
SM1565 12K	40	104	105 gal	4.5L	N/A	6oz	20L
SM1565 6K	40	104	105 gal	4.5L	1.2 gal	6oz	N/A
SM1575 12K	40	104	105 gal	4.5L	N/A	6oz	20L
SM800APC	30	78		4.5L	N/A	6oz	20L
SM212/312	40	104	122 gal	4.5L	N/A	6oz	20L
				Shell Tonna S3M68	Mobil DTE 24	Mobil DTE Light	Mobil Velocite #6
				check daily	check daily	check daily	check daily

SM Series:

Air: 8 CFM @ 80-100 PSI

Air Fitting Size: 5/8 DIA. MINIMUM ID