

SMART
MACHINE TOOL

NL 2500

**Installation
Packet**

NL2500

NL2500

Machine Dimensions

Unit : inch

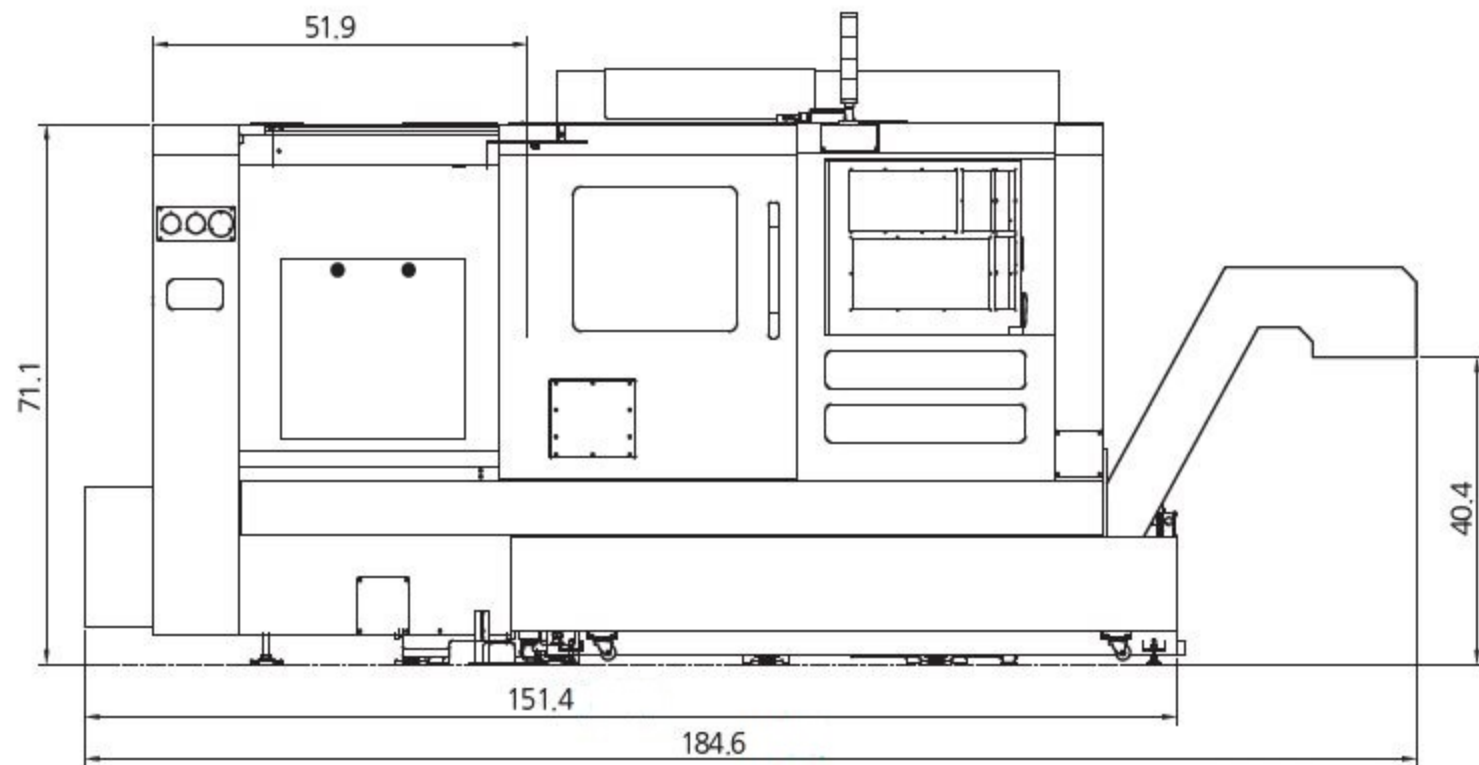

NL2500

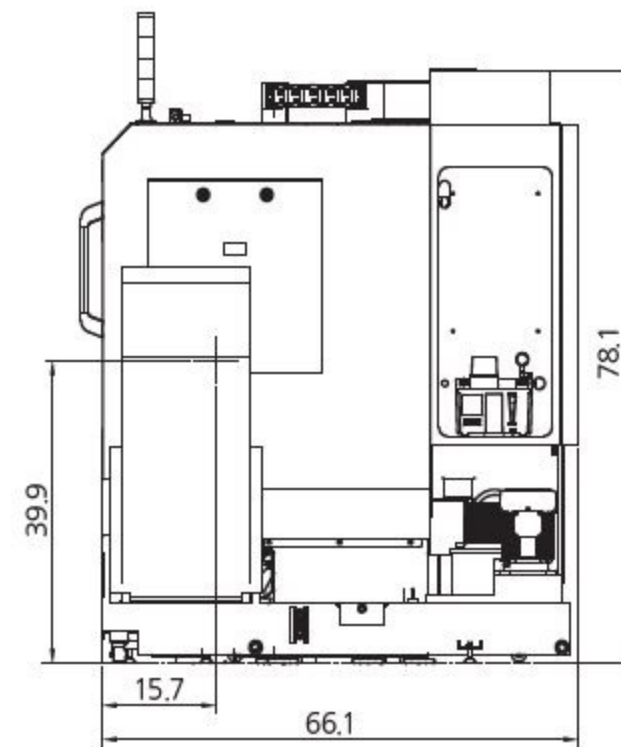

4/24/2018 MACHINE MODEL	KVA	AMPS @ 220	Coolant	Slideways	Hyd. Unit	Transmission	Chuck
NL2000(M)	31	82	48	.79 gal	5.3 gal	n/a	.2 oz daily
NL2500(M)	40	105	53	.79 gal	5.3 gal	0.75	.2 oz daily
NL3000(M)	40	105	63	.79 gal	5.3 gal	0.75	.2 oz daily
NL4000(M)	55	144	63	.79 gal	6.4 gal	0.75	.2 oz daily
NL5000(M)	55	144	63	.79 gal	6.4 gal	0.75	.2 oz daily
NL5000L(M)	65	170	130	.79 gal	6.4 gal	0.75	.2 oz daily
NL6000(M)	65	170	105	.79 gal	15 gal	0.75	.2 oz daily
NL6000L(M)	65	170	150	.79 gal	15 gal	0.75	.2 oz daily
NL7000L(M)	65	170	150	.79 gal	15 gal	2 gal	.2 oz daily
NL7000XL(M)	65	170	180	.79 gal	15 gal	2 gal	.2 oz daily
				Shell Oil T68	Mobil DTE 24	Mobil Oil Light	grease daily
				Mobil Vactra#2		ISO VG 32	
				check daily	check daily	check daily	

Conestoga Trailers arranged by Walsh Logistics required for all machine shipments

Model	Description	ESTIMATED PACKING	
		(Size - FEET)	(Size - LBS)
NL2000(M)	MACHINE	13x7.5x7.5	10,500
NL2500(M)	MACHINE	14.5x7.5x7	13,900
NL2500(M)	CHIP CONVEYOR	12.5x3x5	850
NL3000(M)	MACHINE	15.5x7.5x7	16,500
NL3000(M)	CHIP CONVEYOR	12.5x3x5	870
NL4000(M)	MACHINE	16x7.5x8	25,000
NL4000(M)	CHIP CONVEYOR	14x3.1x5	1,925
NL5000(M)	MACHINE	16x7.5x8	25,500
NL5000(M)	CHIP CONVEYOR	14x3.1x5	1,925
NL5000L(M)	MACHINE	20x7.5x8	32,000
NL5000L(M)	CHIP CONVEYOR	18x3.1x5	2,500
NL6000(M)	MACHINE	18.7x7.5x8.4	35,250
NL6000(M)	CHIP CONVEYOR	15.9x7.5x5.75	2,350
NL6000L(M)	MACHINE		
NL7000L(M)	MACHINE		
NL7000XL(M)	MACHINE		

▽ (▽▽▽, ▽▽, ▽▽▽)

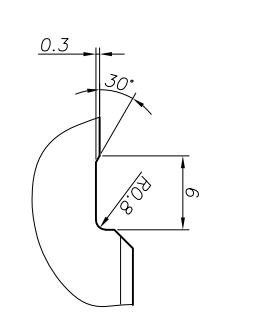
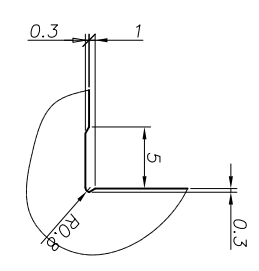
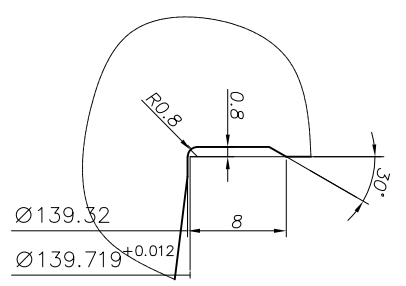
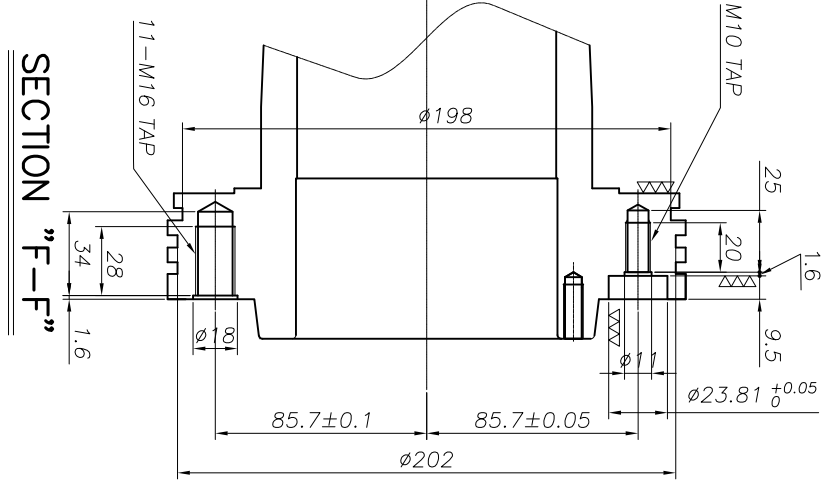
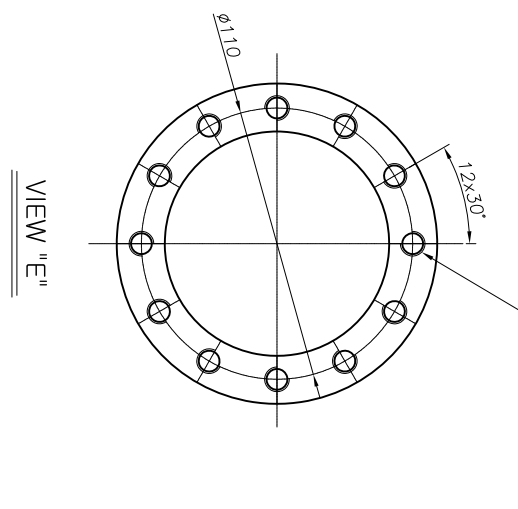
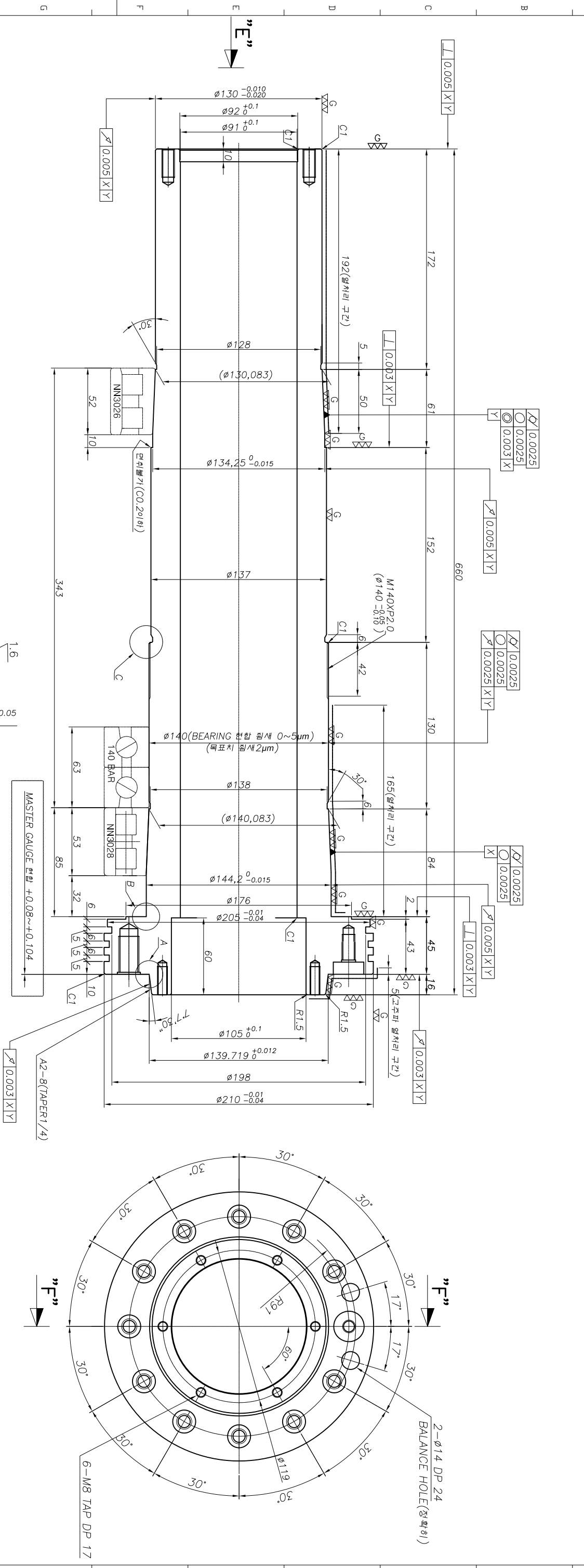

- 주기
- 일반면취 C0.5
 - 주축단 A2-8, 091 사용됨.
 - 정삭 후 조질(HRC24±2)
 - TAPER부 GAUGE 개이지 맞춤(정삭율 85%)
 - 나사부 LOCK NUT 원함 관리 할 것.
 - 주축단 MASTER RINGS GAUGE 원함(+0.08~+0.104)
 - < >는 참고 치수임.

DETAIL "A"
(S=2.5/1)

DETAIL "B"
(S=10/1)

DETAIL "C"
(S=10/1)

MARK	REVISION	DATE	REV'D	CHE'D	DATE	REV'D	CHE'D	DATE	REV'D	CHE'D	DATE	REV'D	CHE'D	DATE	REV'D	CHE'D	
APP'D		J.W. SHIN		GENERAL TOLERANCE		HEAT TREATMENT		SM T K		UNIT ASS'Y		HEAD STOCK		MAIN SPINDLE(A2-8)		SCALE	
DES'N		J.S. PARK		MATERIAL		SM45C		1/1.5		N 2530102A00							
DATE		2018.12.17		MATERIAL		SM45C		1/1.5		N 2530102A00							
DATE		2018.12.17		MATERIAL		SM45C		1/1.5		N 2530102A00							