

SMART
MACHINE TOOL

VX350

**Installation
Packet**

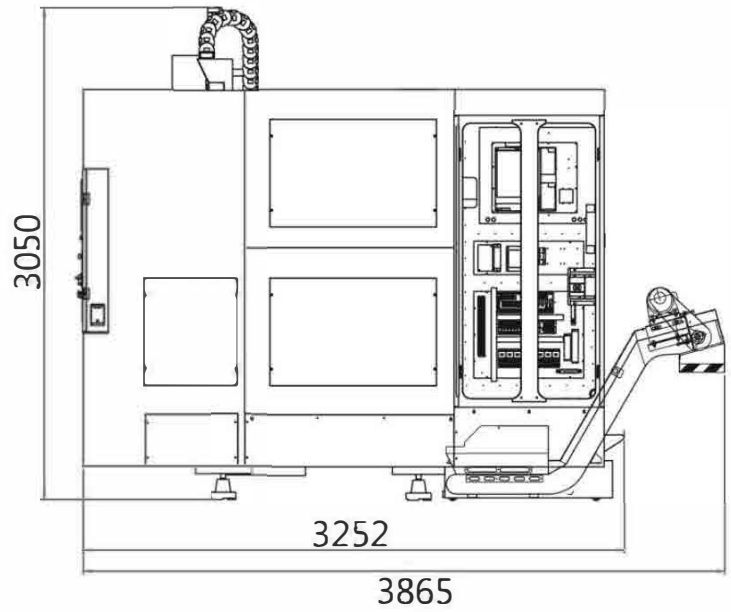

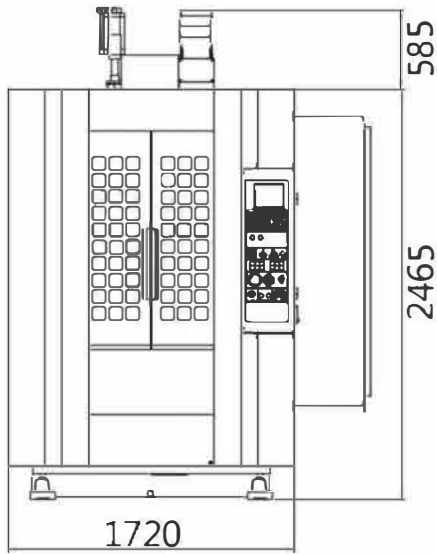
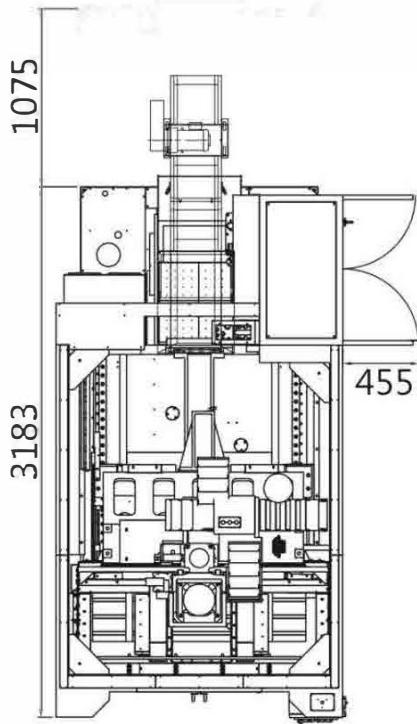
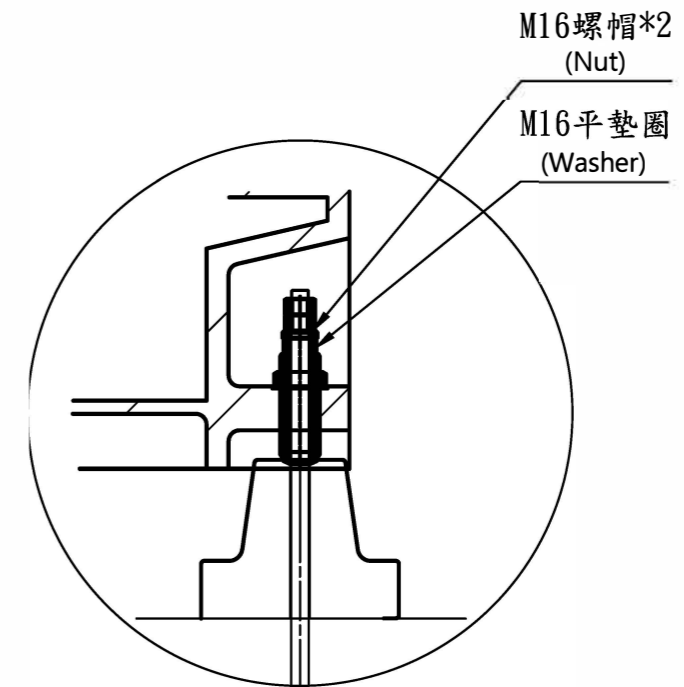
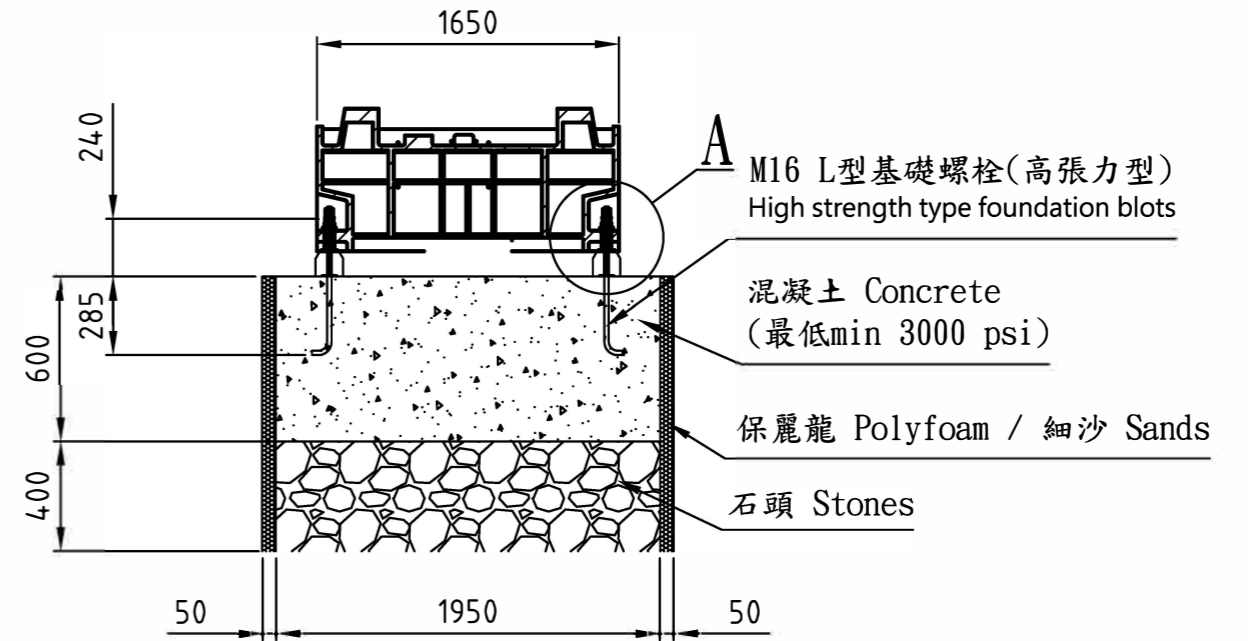
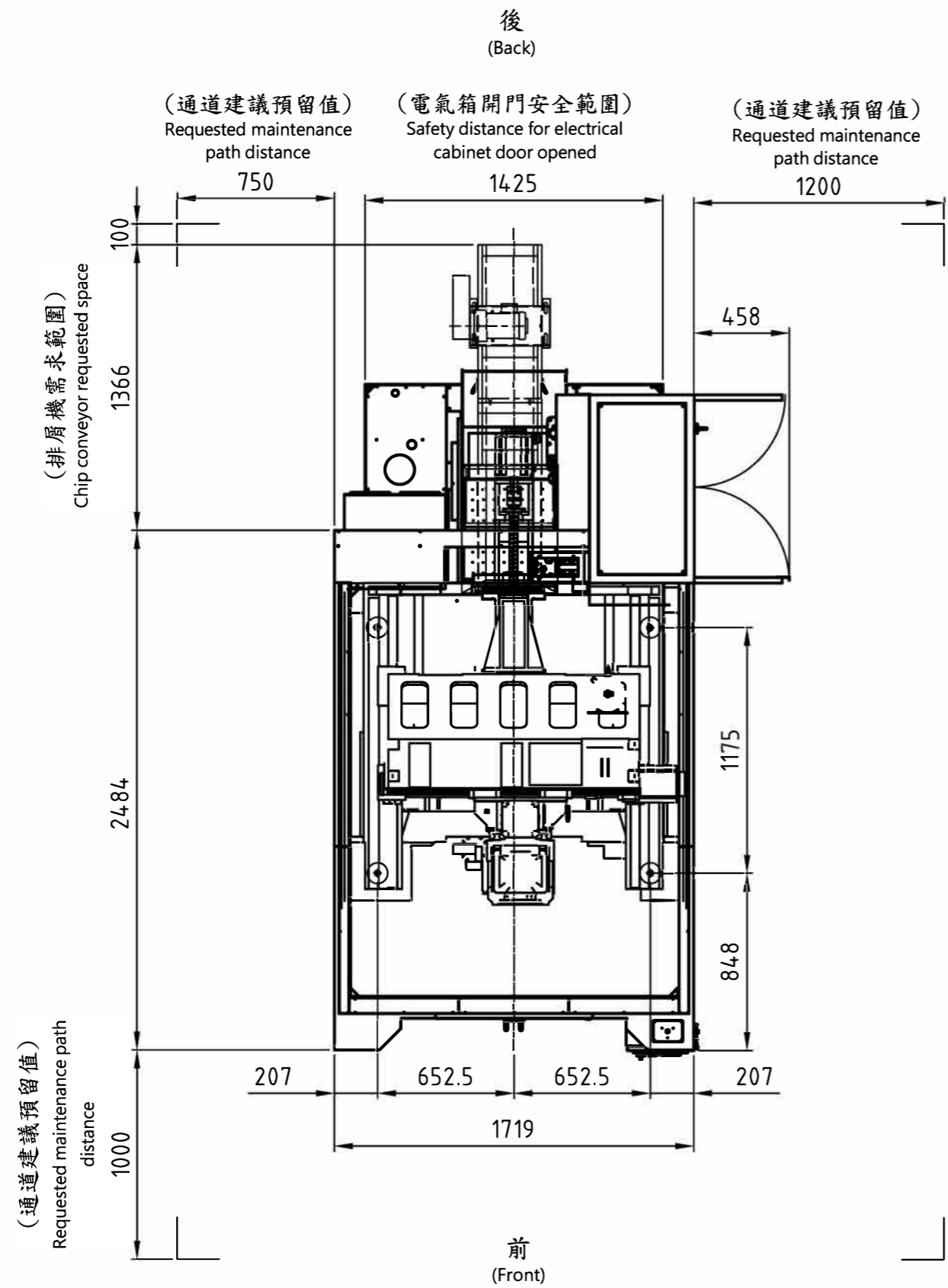

細部放大視圖 A

※機台安全工作高度為3200mm
(Machine safety installation height 3200mm)

#40

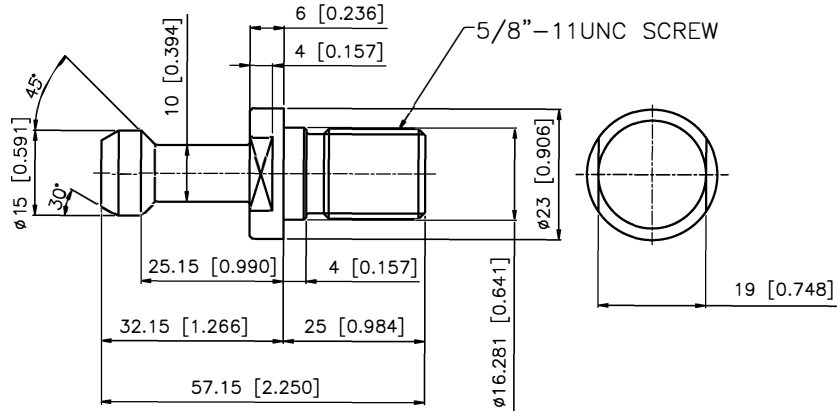

#50

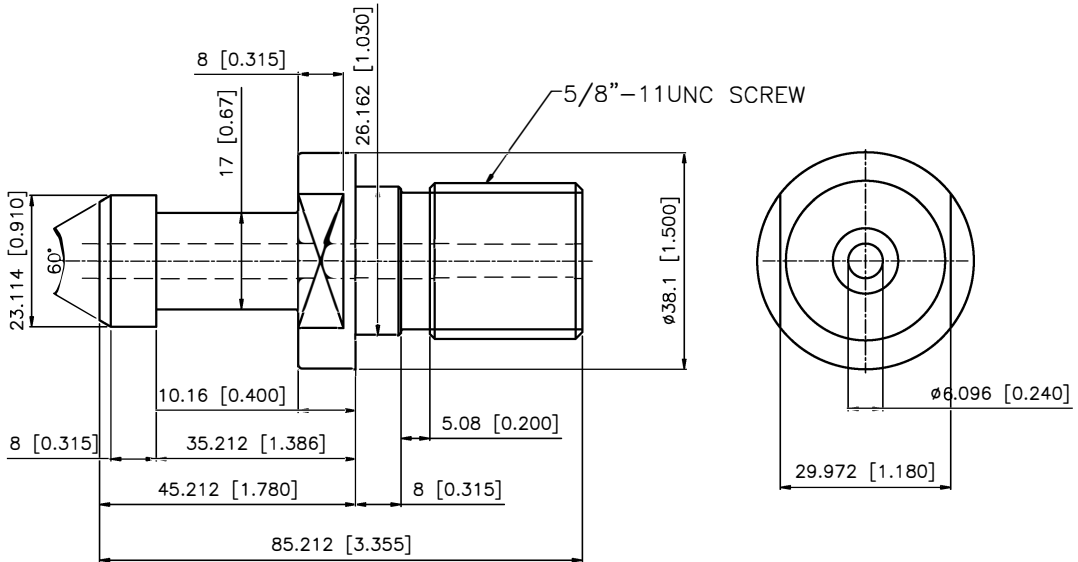

SMART MACHINE TOOL

| VX350 Specs | |
|-------------|------------|
| Length | 14 ft |
| Width | 7.6 ft |
| Height | 8.4 ft |
| Weight | 15,652 lbs |
| KVA | 25 |

RECOMMENDED LUBRICATION & COOLANT TABLE

| PART | CAPACITY | RECOMMENDED LUBRICATION/COOLANT | TIME TO CHECK OUT | REMARK |
|----------------------------------------|------------------------------------|-----------------------------------------------------|-----------------------------------------------------------------------------------|----------------------------------------------------------------------------------------|
| Transmission system (Lubricating oil) | 2 L | ISO VG68 | Should be checked daily. Should be appended immediately when the level is low. | Should check the lubrication system immediately when there is no lubrication consuming |
| Transmission system (Cartridge grease) | 0.7 L | LHL-X100 | | |
| Coolant (For cutting) | 200L | According to the parts material you want to machine | Should be checked daily Should be appended immediately when the level is low | Please clean the tank filter weekly. |
| Pneumatic system | 50 mL | ISO VG3 | Should be checked daily Should be appended immediately when the level is low | According to the machine model. Some models without this lubrication |
| Spindle Chiller | 20 L | ISO VG10 | Should be checked daily Should be appended immediately when the level is low | Should be renewed per year. |
| Hydraulic system | Refer to machine model | ISO VG32 | Should be checked daily Should be appended immediately when the level is low | Should be renewed per year. |
| Rotary table fourth or fifth | Refer to the model of rotary table | ISO VG100 | Should be checked monthly | Should be renewed per year. |
| ATC (Arm type) | 7L | ISO VG200 | Should be checked monthly | Should be renewed per year. |