

**SMART**  
MACHINE TOOL

**SM 1165**

**Installation  
Packet**

c. SM965/1165/1365/1565 36t CHIP CONVEYOR

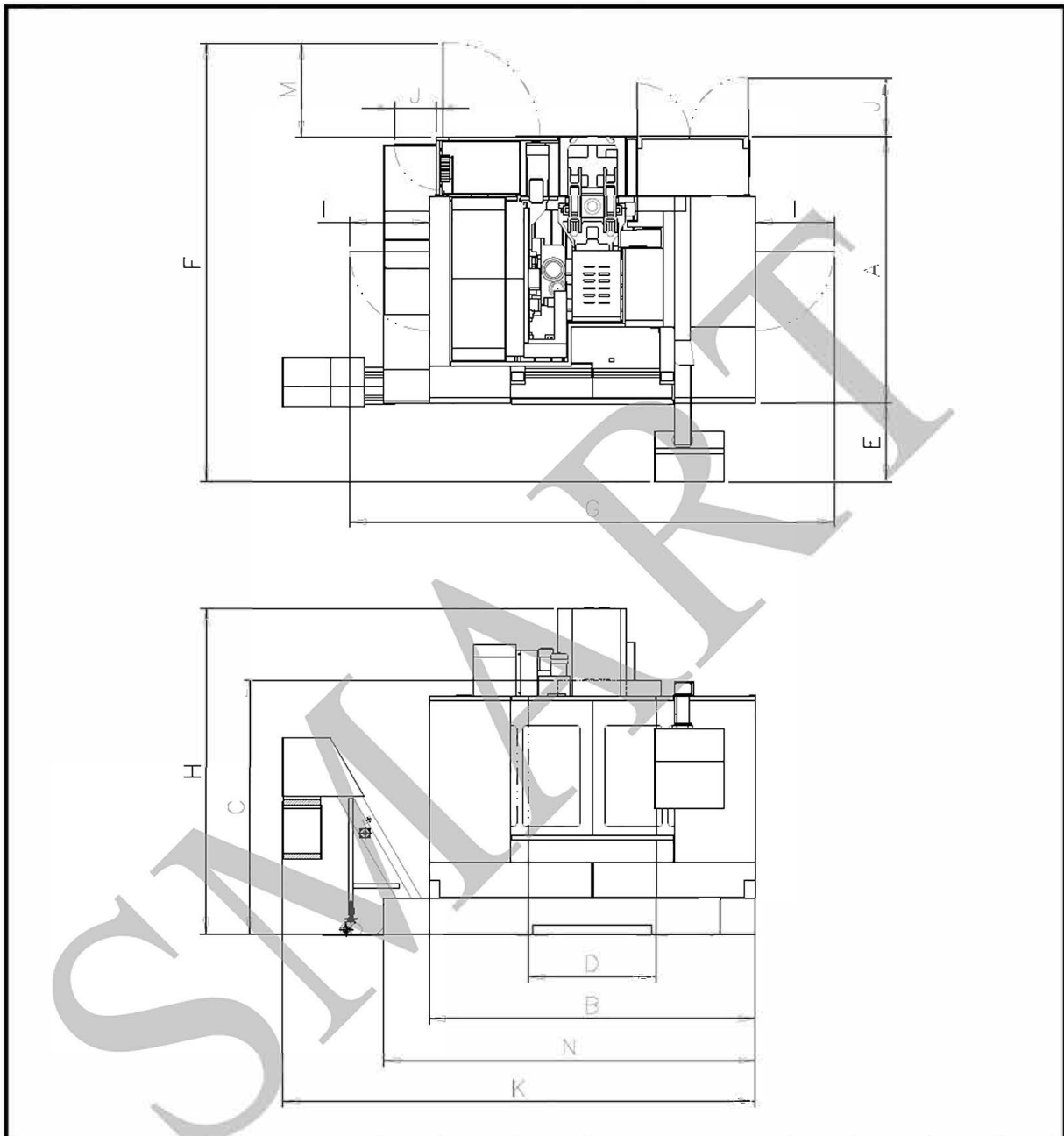

Model	A	B	C	D	E	F	G	H	I	J	K	L	M	N
SM965	2,231	2,720	2,297	1,050	656	3,667	4,040	2,907	660	467	3,943	381	791	3,100
SM1165		3,170		1,270			4,490				4,393			3,434
SM1365		3,450		1,450			4,770				4,673			3,730
SM1565		3,850		1,620			5,170				5,073			4,130

b. SM1165

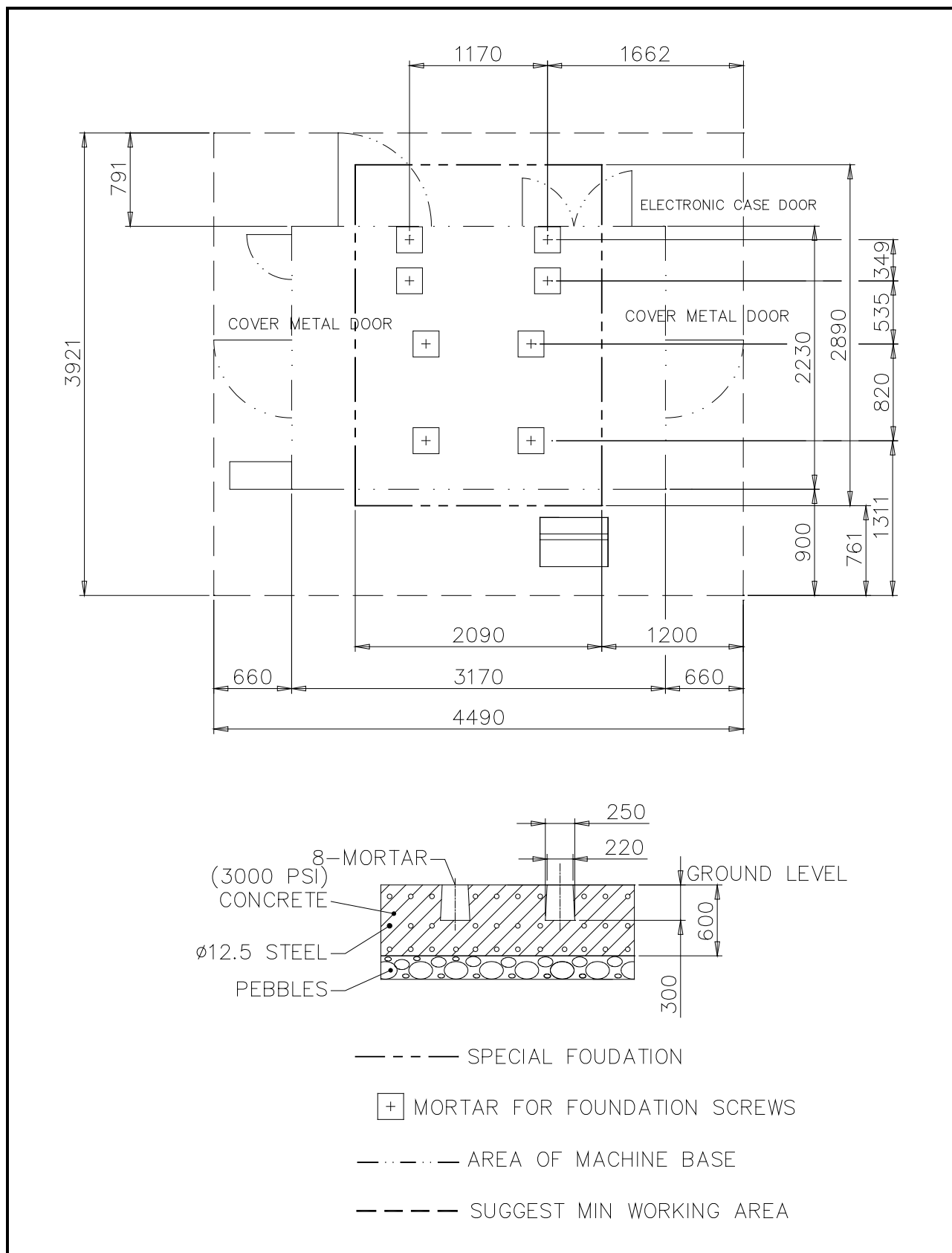

#40

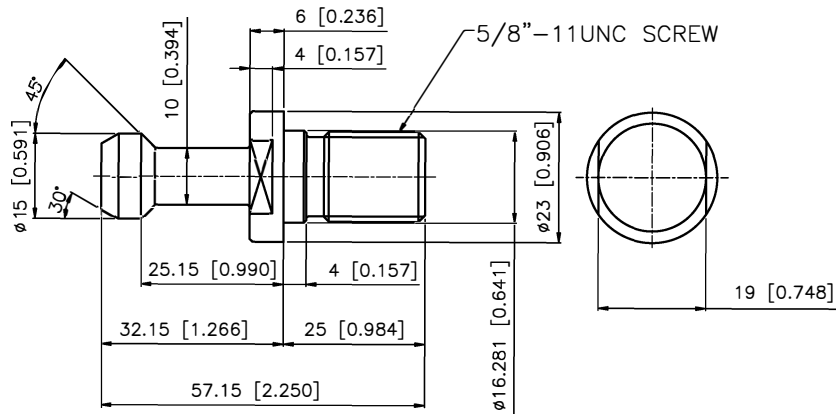

Lyndex PN  
Non CTS  
C40-4500  
CTS  
C40-4500H

#50

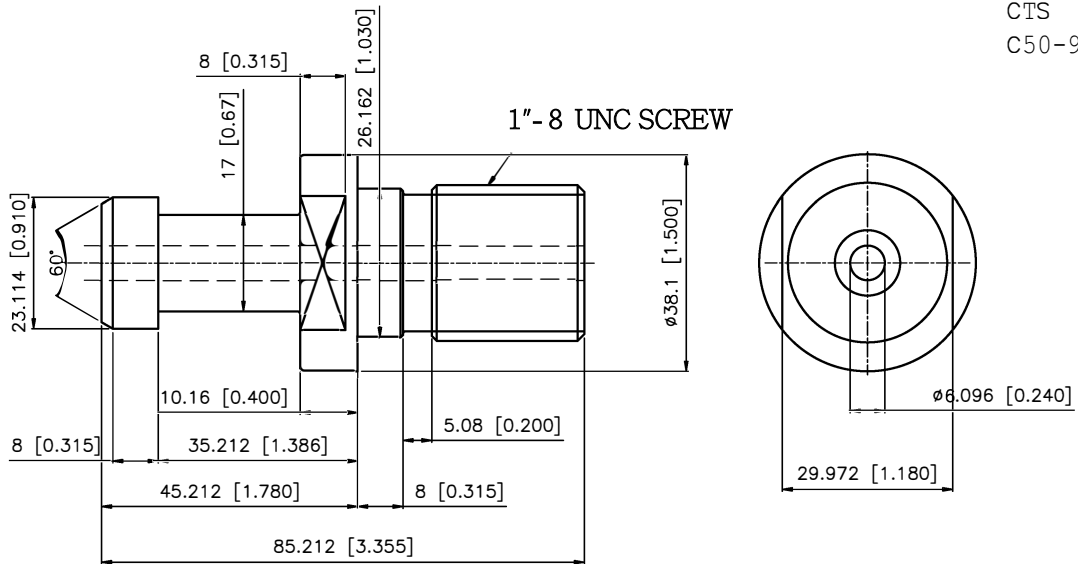

Lyndex PN  
Non CTS  
C50-9000  
CTS  
C50-9000H

**POWER AND LUBRICATION REQUIREMENTS**

10/1/2018 MACHINE MODEL	KVA	AMPS @ 220	Coolant	Slideways	Chilled Geared Headstock	Oil for Air	Chiller OilTank
<b>SM850</b>	25	65	87 gal	6L	N/A	6oz	20L
<b>SM1000</b>	25	65	89 gal	6L	N/A	6oz	20L
<b>SM1688</b>	45	118	116 gal	6L	20L	6oz	N/A
<b>SM2600</b>	50	131	360 gal	6L	20L	6oz	N/A
				Shell Tonna S3M68		Mobil DTE Light	Mobil Velocite #3
<b>SM965 8K</b>	25	65	95 gal	4.5L	1.2 gal	6oz	N/A
<b>SM965 12K</b>	40	104	95 gal	4.5L	N/A	6oz	20L
<b>SM1165 8K</b>	25	65	99 gal	4.5L	1.2 gal	6oz	N/A
<b>SM1165 12K</b>	40	104	99 gal	4.5L	N/A	6oz	20L
<b>SM1165 6K</b>	40	104	99 gal	4.5L	1.2 gal	6oz	N/A
<b>SM1365 6K</b>	40	104	103 gal	4.5L	1.2 gal	6oz	N/A
<b>SM1365 12K</b>	40	104	103 gal	4.5L	N/A	6oz	20L
<b>SM1565 12K</b>	40	104	105 gal	4.5L	N/A	6oz	20L
<b>SM1565 6K</b>	40	104	105 gal	4.5L	1.2 gal	6oz	N/A
				Shell Tonna S3M68	Mobil DTE 24	Mobil DTE Light	Mobil Velocite #6
				check daily	check daily	check daily	check daily

**MCV Series:**

Air: 8 CFM @ 80-100 PSI

Air Fitting Size: 5/8 DIA. MINIMUM ID

Conestoga Trailers arranged by Walsh Logistics required for machine shipments

Model	Description	ESTIMATED PACKING	
		(Size - INCHES)	(Size - LBS)
SM850	MACHINE	9'2 x 7'7 x 8'1	9,259
SM850	ACCESSORIES	9' x 7'3 x3'1	1,003
SM1000	MACHINE	9'7 X 7'7 X 8'6	12,787
SM1000	ACCESSORIES	10'5 X 7'3 X 6'5	1,874
SM965	MACHINE	11'2 x 7'7 x 8'3	15,783
SM1165-8K	MACHINE	12'3 X 7'7 X 8'3	15,432
SM1165-6K	MACHINE	16'1 X 7'7 X 8'3	16,424
SM1165-6K	TOOL MAGAZINE	5'4 X 3'7 X 5'6	1,984
SM1165-12K	MACHINE	16'1 X 7'7 X 8'2	15,432
SM1165-12K	TOOL MAGAZINE	3'1 X 3'8 X 4'2	1,433
SM1365	MACHINE	16'3 X 7'7 X 8'1	16,755
SM1365	TOOL MAGAZINE	3'7 X 5'4 X 5'6	1,984
SM1565	MACHINE	17'8 x 7'7 x 8'1	18,298
SM1565	TOOL MAGAZINE	3'7 x 5'5 x 5'5	1,984
SM1688	MACHINE & ACCESSORIES	17'9 X 13'6 X 11'3	42,064
SM2600	MACHINE	17'9"x13'2"x13'	47,399
SM2600	ACCESSORIES	18'1"x7'6"x6'5"	5,512
SM2600	ACCESSORIES	15'9"x7'6"x7'8"	7,716
SM800-APC	MACHINE	11'9 x 7'7 x 8'3	16,535
SM800-APC	ACCESSORIES(tool magazine, chip conveyor, etc.)	13' x 7'6 x 6'4	3,616
Conestoga not required for SM1688 and SM2600			